

W3G800-GG95-90
 ebm-papst Ventilator

EC axial fan - HyBlade

sickle-shaped blades (S series)
 with square full nozzle

ASIA PACIFIC SHENGRUI LIMITED

Phone +00852 56261528
 info@apacfan.com
 www.apacfan.com

Nominal data

Type	W3G800-GG95-90	
Motor	M3G112-IA	
Phase		3~
Nominal voltage	VAC	400
Nominal voltage range	VAC	380 .. 480
Frequency	Hz	50/60
Method of obtaining data		ml
Speed (rpm)	min ⁻¹	770
Power consumption	W	900
Current draw	A	1.5
Max. back pressure	Pa	120
Max. back pressure	in. wg	0.48
Min. ambient temperature	°C	-25
Max. ambient temperature	°C	60

ml = Max. load · me = Max. efficiency · fa = Free air · cs = Customer specification · ce = Customer equipment
 Subject to change

Data according to Commission Regulation (EU) 327/2011

		Actual	Req. 2015
01 Overall efficiency η_{es}	%	40.9	33.2
02 Measurement category		A	
03 Efficiency category		Static	
04 Efficiency grade N		47.7	40
05 Variable speed drive		Yes	

Data obtained at optimum efficiency level.
 The ErP data is determined using a motor-impeller combination in a standardized measurement setup.

09 Power consumption P_{ed}	kW	0.85
09 Air flow q_v	m ³ /h	11970
09 Pressure increase p_{fs}	Pa	97
10 Speed (rpm) n	min ⁻¹	770
11 Specific ratio*		1.00

* Specific ratio = $1 + p_{fs} / 100\,000\text{ Pa}$

LU-166374



W3G800-GG95-90
ebm-papst Ventilator

EC axial fan - HyBlade

sickle-shaped blades (S series)
with square full nozzle

Technical description

Weight	31.9 kg
Fan size	800 mm
Rotor surface	Painted black
Terminal box material	PP plastic
Electronics housing material	Die-cast aluminum, painted black
Blade material	Press-fitted sheet steel blank, sprayed with PP plastic
Fan housing material	Sheet steel, galvanized and coated with black plastic (RAL 9005)
Guard grille material	Steel, coated with black plastic (RAL 9005)
Number of blades	5
Airflow direction	"V"
Direction of rotation	Clockwise, viewed toward rotor
Degree of protection	IP55
Insulation class	"F"
Moisture (F) / Environmental (H) protection class	H2
Ambient temperature note	Occasional start-up between -40°C and -25°C is permissible. For continuous operation at temperatures below -25°C (e.g. refrigeration applications) we recommend our fan design with special low-temperature bearings.
Max. permitted ambient temp. for motor (transport/storage)	+ 80 °C
Min. permitted ambient temp. for motor (transport/storage)	- 40 °C
Installation position	Shaft horizontal or rotor on bottom; rotor on top on request
Condensation drainage holes	On rotor side
Mode	S1
Motor bearing	Ball bearing; (sealed)
Technical features	<ul style="list-style-type: none">- Output 10 VDC, max. 10 mA- Operation and alarm display- External 24 V input (parameter setting)- Alarm relay- Integrated PID controller- Power limiter- Motor current limitation- PFC, passive- RS-485 MODBUS-RTU- Soft start- EEPROM write cycles: 100,000 maximum- Control input 0-10 VDC / PWM- Control interface with SELV potential safely disconnected from the mains- Temperature derating- Thermal overload protection for electronics/motor- Line undervoltage / phase failure detection
EMC immunity to interference	According to EN 61000-6-2 (industrial environment)
EMC circuit feedback	According to EN 61000-3-2/3
EMC interference emission	According to EN 61000-6-3 (household environment)
Touch current according to IEC 60990 (measuring circuit Fig. 4, TN system)	<= 3.5 mA
Electrical hookup	Via terminal box



W3G800-GG95-90
ebm-papst Ventilator

EC axial fan - HyBlade

sickle-shaped blades (S series)
with square full nozzle

Motor protection	Thermal overload protector (TOP) internally connected
Protection class	I (with customer connection of protective earth)
Conformity with standards	EN 61800-5-1; CE
Approval	UL 1004-7 + 60730; C22.2 No.77 + CAN/CSA-E60730-1; EAC
Comment	Conformity with EN 60335-1 in preparation



EC axial fan - HyBlade

sickle-shaped blades (S series)
 with square full nozzle

Product drawing

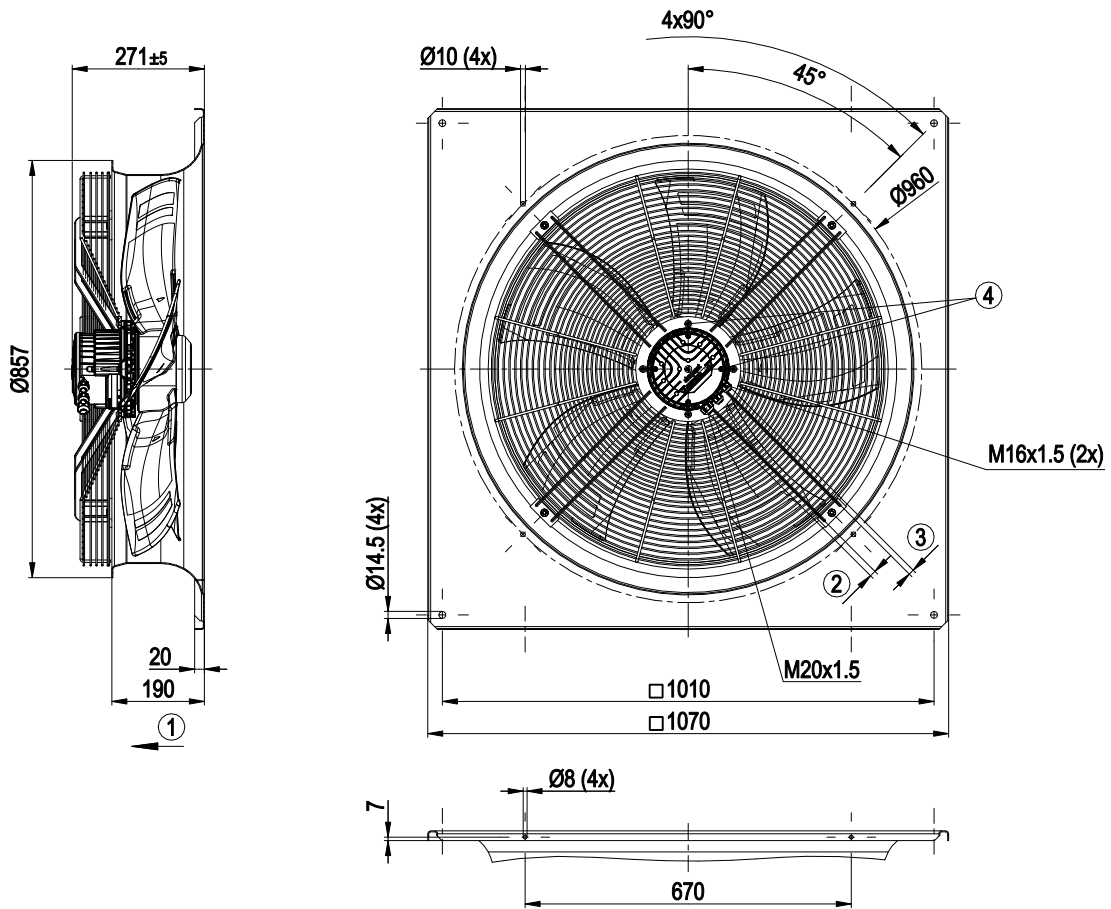

1	Airflow direction "V"
2	Cable diameter min. 8 mm, max. 12 mm, tightening torque 2.5 ± 0.4 Nm
3	Cable diameter min. 6 mm, max. 10 mm, tightening torque 2.5 ± 0.4 Nm Cable diameter min. 4 mm, max. 7 mm, tightening torque 2.5 ± 0.4 Nm (included seal must be used)
4	Tightening torque 1.5 ± 0.2 Nm

EC axial fan - HyBlade

sickle-shaped blades (S series)
 with square full nozzle

Connection diagram

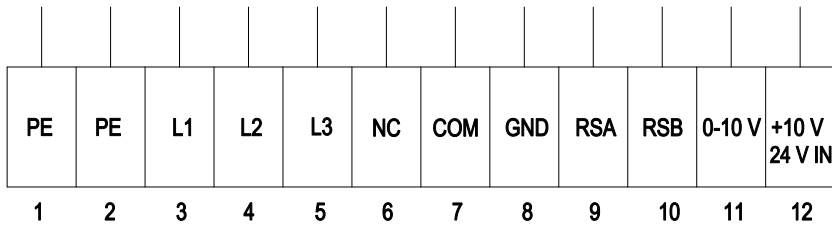

No.	Conn.	Designation	Function/assignment
1	PE	PE	Protective earth
2	PE	PE	Protective earth
3	L1	L1	Power supply
4	L2	L2	Power supply
5	L3	L3	Power supply
6	NC	NC	Status relay, floating status contact, break for failure, contact rating 250 VAC / 2 A (AC1) / min. 10 mA; reinforced insulation on supply side and basic insulation on control interface side
7	COM	COM	Status relay, floating status contact, break for failure, contact rating 250 VAC / 2 A (AC1) / min. 10 mA; reinforced insulation on supply side and basic insulation on control interface side
8	GND	GND	Reference ground for control interface, SELV
9	RSA	RSA	RS485 interface for MODBUS, RSA; SELV
10	RSB	RSB	RS485 interface for MODBUS, RSB; SELV
11	0-10 V	0-10 V	Analog input (set value) SELV, 0-10 V, Ri = 100 kΩ, adjustable curve
12	+10 V	+10 V	Fixed voltage output 10 VDC, SELV, +10 V ±3%, max. 10 mA, short-circuit-proof, power supply for external devices (e.g. pot); fixed voltage input 24 VDC for setting parameters via MODBUS without line voltage supply



Curves: Air performance 50 Hz

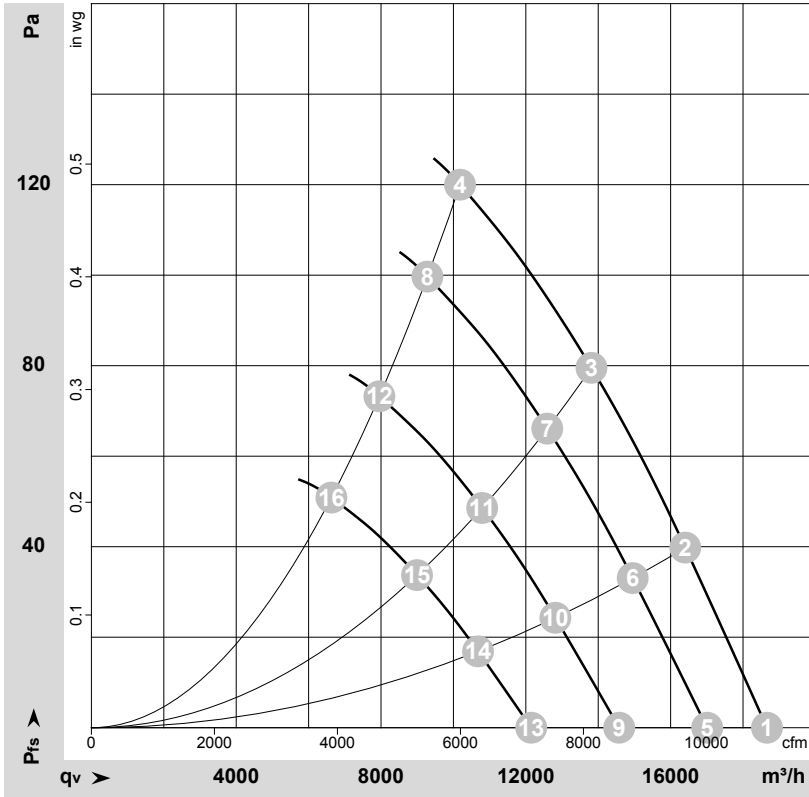

$\rho = 1.15 \text{ kg/m}^3 \pm 2 \%$

Measurement: LU-155353-1

Air performance measured according to ISO 5801 installation category A. For detailed information on the measurement setup, contact ebm-papst. Intake sound level: Sound power level according to ISO 13347 / sound pressure level measured at 1 m distance from fan axis. The values given are valid under the specified measuring conditions and may vary due to conditions of installation. For deviations from the standard configuration, the parameters have to be checked on the installed unit.

Measured values

	U	f	n	P _{ed}	I	LpA _{in}	LwA _{in}	LwA _{out}	q _v	P _{fs}	q _v	P _{fs}
	V	Hz	min ⁻¹	W	A	dB(A)	dB(A)	dB(A)	m ³ /h	Pa	cfm	in. wg
1	400	50	770	550	0.93	63	70	70	18660	0	10985	0.00
2	400	50	770	670	1.12	60	67	66	16405	40	9655	0.16
3	400	50	770	780	1.29	58	65	65	13815	80	8130	0.32
4	400	50	770	900	1.50	66	73	73	10185	120	5995	0.48
5	400	50	700	417	0.71	61	68	68	17010	0	10010	0.00
6	400	50	700	508	0.85	57	64	64	14950	33	8800	0.13
7	400	50	700	590	0.98	56	63	62	12595	66	7410	0.26
8	400	50	700	678	1.12	63	71	71	9280	100	5465	0.40
9	400	50	600	262	0.45	57	64	64	14580	0	8580	0.00
10	400	50	600	320	0.53	53	61	60	12815	24	7545	0.10
11	400	50	600	372	0.62	52	59	58	10795	49	6355	0.20
12	400	50	600	427	0.70	59	67	67	7955	73	4680	0.29
13	400	50	500	152	0.26	52	59	59	12150	0	7150	0.00
14	400	50	500	185	0.31	49	56	55	10680	17	6285	0.07
15	400	50	500	215	0.36	47	54	54	8995	34	5295	0.14
16	400	50	500	247	0.41	55	62	62	6630	51	3900	0.20

U = Power supply · f = Frequency · n = Speed (rpm) · P_{ed} = Power consumption · I = Current draw · LpA_{in} = Sound pressure level intake side · LwA_{in} = Sound power level intake side
 LwA_{out} = Sound power level outlet side · q_v = Air flow · P_{fs} = Pressure increase