

Product Data Sheet 2218F/2TDH40R-230

ebmpapst

The engineer's choice



2218F/2TDH4OR-230

INDEX

1	General	3
2	Mechanics	3
2.1	General	3
2.2	Connections	3
3	Operating Data	5
3.1	Electrical Interface - Input	5
3.2	Electrical Operating Data	7
3.3	Electrical Interface - Output - Tacho	8
3.4	Electrical Features	9
3.5	Aerodynamics	11
3.6	Sound Data	12
4	Environment	12
4.1	General	12
4.2	Climatic Requirements	12
4.3	Mechanical Requirements	13
5	Safety	15
5.1	Electrical Safety	15
5.2	Approval Tests	15
6	Reliability	15
6.1	General	15

1 General

Fan type	Axial fan	
Rotating direction looking at rotor	Counterclockwise	
Airflow direction	Air outlet over struts	
Bearing system	Ball bearing	
Mounting position - shaft	Any	

2 Mechanics**2.1 General**

Width	200 mm	
Height	200 mm	
Depth	51 mm	
Diameter	220 mm	
Mass	1,06 kg	
Housing material	Metal	
Impeller material	Plastic	

2.2 Connections

Electrical connection	Wires	
Lead wire length	L = 450 mm	
Tolerance	+ - 10 mm	
Tube length	S = 410 mm	
Tolerance	+ - 10 mm	

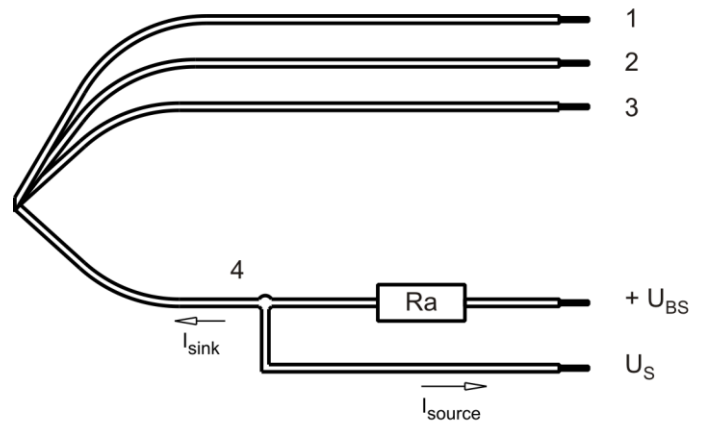

Wire	Color	Operation	Wire size	Insulation diameter
1	red	+ UB	AWG 18	2,2 mm
2	blue	- GND	AWG 18	2,2 mm
3	violet	CONTR	AWG 22	1,7 mm
4	white	Tacho	AWG 22	1,7 mm

The auxiliaries shown on the schematic diagram (which are required for the intended use) are not part of our delivery.

3 Operating Data

3.1 Electrical Interface - Input

Control input	Analog
---------------	--------

Features

PWM - Frequency	1 kHz - 10 kHz typical: 2 kHz
Input voltage range	0 V - 10 V

Characteristics

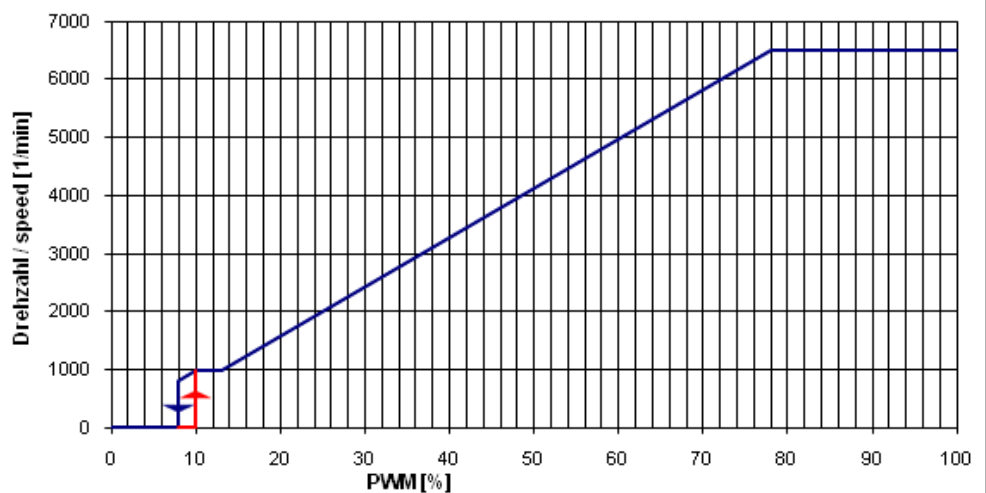
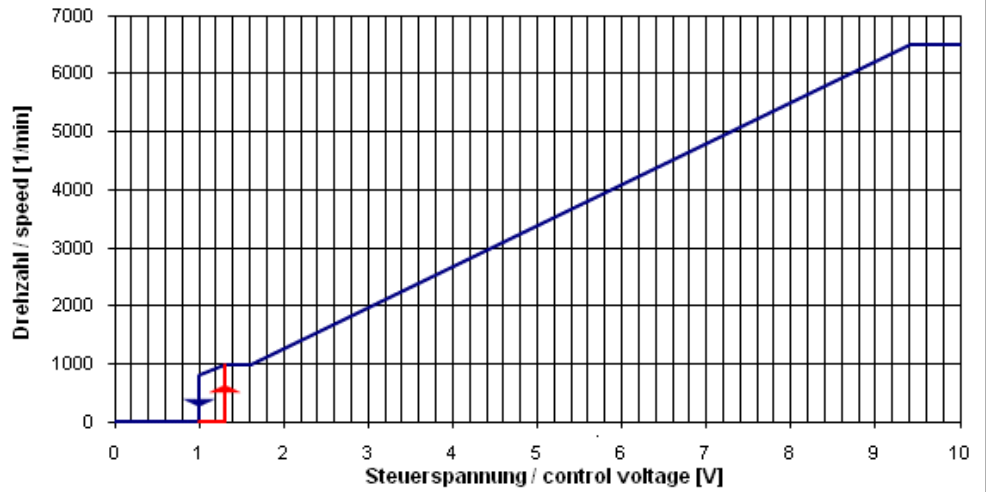

Schematics

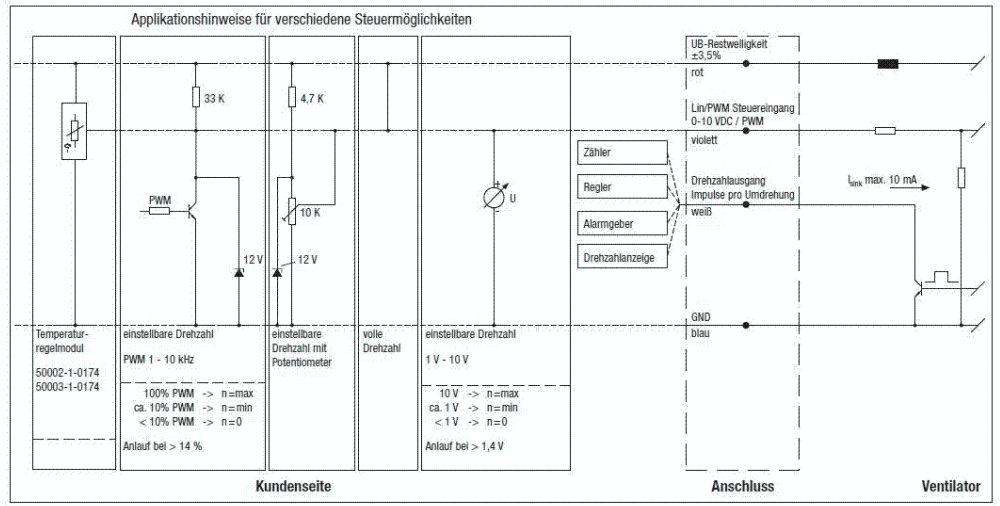
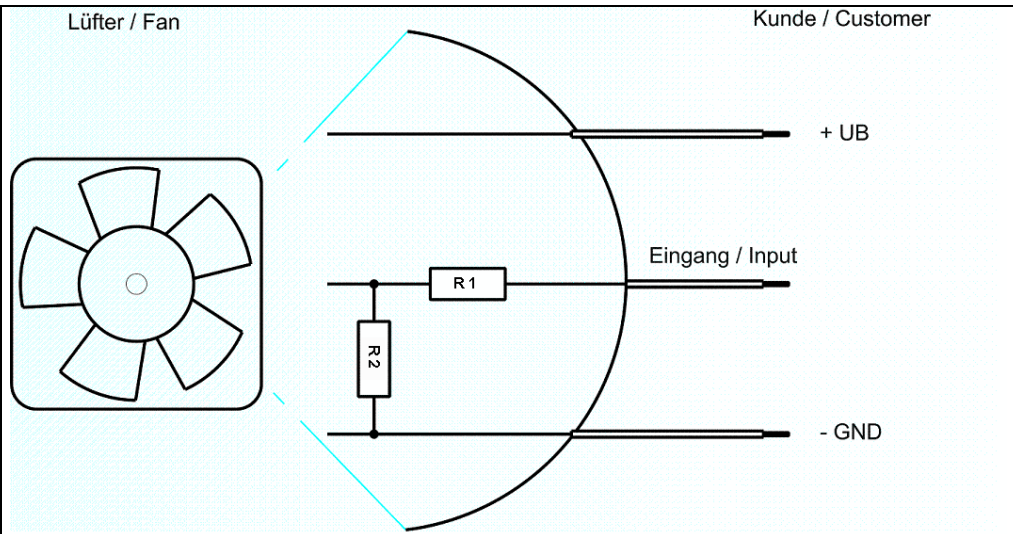

Input voltage divider:

R1 = 47 kOhm

R2 = 36 kOhm

For protection: There is a 5,1 V Z-Diode in parallel to R2.

Speed control:

By pulse-width modulation (PWM) 0 ... 100%
 with switching transistor in emitter circuit and collector resistor to 12 V
 Frequency = 2 kHz (1 - 10 kHz)

Information to the curve PWM:

- 0% - <10% PWM: 0 1/min
- 10% PWM: 1.000 1/min (Fan on, coming from 0% PWM)
- 10% - 13% PWM: 1.000 1/min (corresponding to min. speed)
- 13% - 78% PWM: linear increasing curve
- 78% - 100% PWM: 6.600 1/min (corresponding to max. speed)
- 10% - >8% PWM: linear decreasing curve (coming from 100% PWM)
- 8% PWM: 800 1/min or 0 1/min (Fan off, coming from 100% PWM)

or:

Speed control:

By analog voltage 0 - 10 V

Information to the curve analog:

0 V - < 1,3 V:	0 1/min
1,3 V:	1.000 1/min (Fan on, coming from von 0 V)
1,3 V - 1,6 V:	1.000 1/min (corresponding to min. speed)
1,6 V - 9,4 V:	linear increasing curve
9,4 V - 10 V:	6.600 1/min (corresponding to max. speed)
1,3 V - > 1,0 V:	linear decreasing curve (coming from 10 V)
1,0 V:	800 1/min or 0 1/min (Fan off, coming from 10 V)

Note:

It must be ensured that the power supply is applied before the control signal (U Contr) is turned on. The fan has no sensor break detection. This means - when the input is not connected, the speed is set to zero.

3.2 Electrical Operating Data

Measurement conditions: Normal air density = 1,2 kg/m³; Temperature 23°C +/- 3°C; Motor axis horizontal; warm-up time before measuring 5 minutes (unless otherwise specified). In the intake and outlet area should not be any solid obstruction within 0,5 m.

$\Delta p = 0$: corresp. to free air flow (see section 3.5)
 I: corresp. to arithm. mean current value

Name	Condition
U Contr. 0001	U Contr.: 10 V

Features	Condition	Symbol	Values		
Voltage range		U	36 V		72 V
Nominal voltage		U _N		48 V	
Power consumption	$\Delta p = 0$	P	76 W	103 W	108 W
Tolerance	U Contr. 0010		+/- 15 %	+/- 10 %	+/- 10 %
Current consumption	$\Delta p = 0$	I	2.100 mA	2.150 mA	1.500 mA
Tolerance	U Contr. 0010		+/- 15 %	+/- 10 %	+/- 10 %
Speed	$\Delta p = 0$	n	5.900 1/min	6.500 1/min	6.500 1/min
Tolerance	U Contr. 0010		+/- 10 %	+/- 3 %	+/- 3 %

3.3 Electrical Interface - Output - Tacho

Tacho type	/2 (open collector)
------------	---------------------

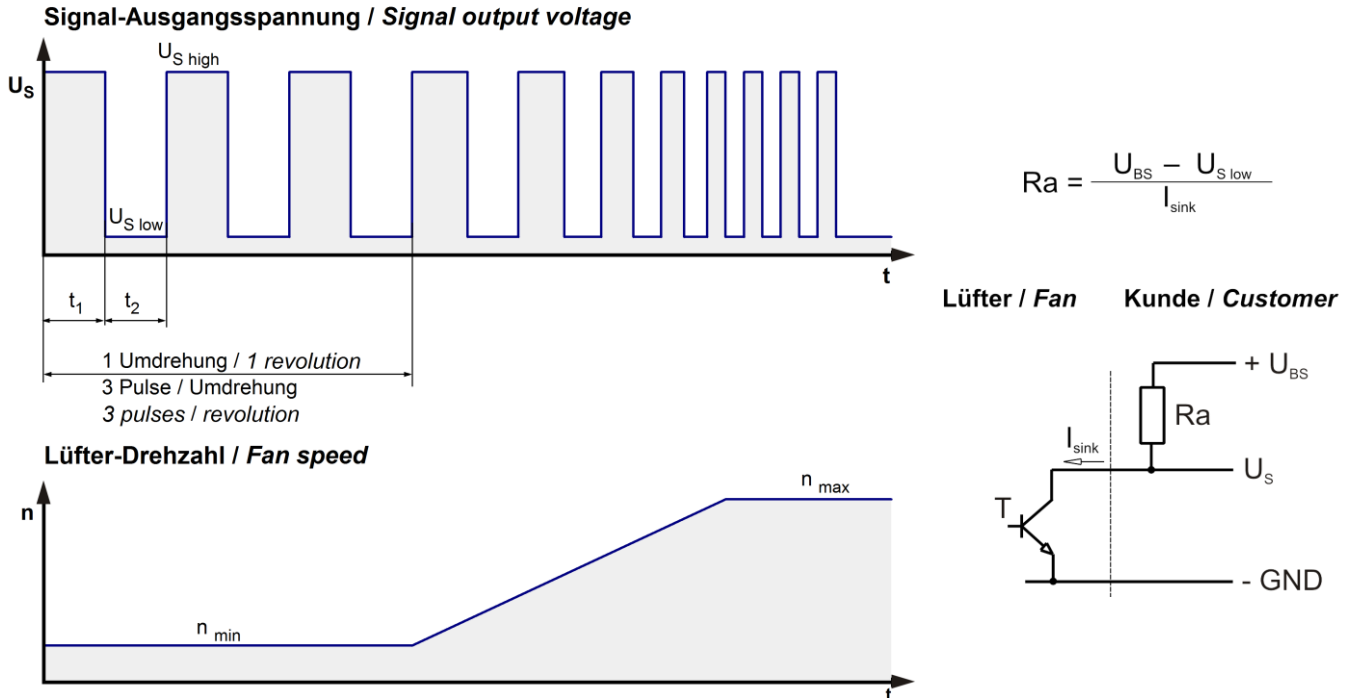

Features	Note	Values
Tacho operating voltage	U_{BS}	$\leq 60\text{ V}$
Tacho signal Low	$U_{S\ low}$	$\leq 0,4\text{ V}$
Tacho signal High	$U_{S\ high}$	$\leq 60\text{ V}$
Maximum sink current	I_{sink}	$\leq 20\text{ mA}$
External resistor	External resistor R_a from U_{BS} to U_S required. All voltages measured to GND.	
Tacho frequency	$(3 \times n) / 60$	325 Hz @ 6.500 1/min
Tacho isolated from motor	No	
Slew rate		$\Rightarrow 0,5\text{ V/us}$

n = revolutions per minute (1/min)

3.4 Electrical Features

Electronic function	Speed-Controlled	
Reversed polarity protection	P-CH FET	
Max. residual current at U_N	$I_F \leq 5 \text{ mA}$	
Locked rotor protection	Auto restart	
Locked rotor current at U_N	I_{block} approx. 2.000 mA	
Clock signal at locked rotor	t_3 / t_4 typical: 3,0 s / 10,0 s	
Extended Downtime	t_5 : 40 s after 4 start-up tests	
Internal fuse	Littelfuse NANO2 > Very Fast-Acting > 451/453 Series 10A / 125V (Art.No.: 0451010.MRL)	
Voltage control *)	Einschalten bei $U_B > 34 \text{ V}$ oder $< 78 \text{ V}$ Ausschalten bei $U_B < 32 \text{ V}$ oder $> 80 \text{ V}$	

*) This fan has an undervoltage and overvoltage control circuit integrated which turns the motor off if the voltage is out of range.

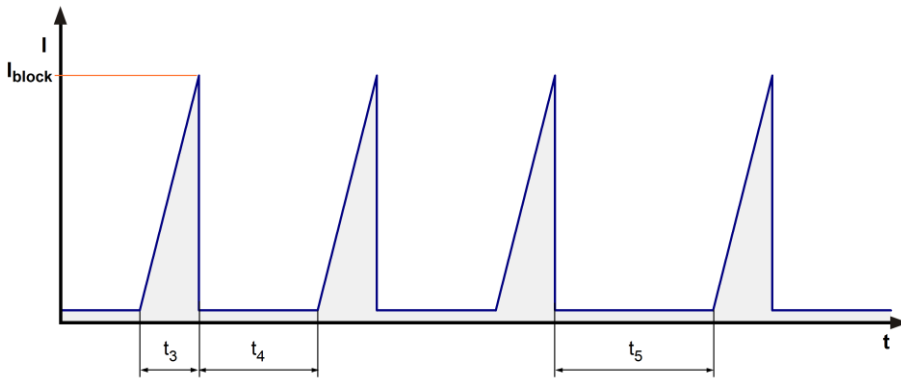

The locked rotor current is measured as peak current at nominal voltage. After 3 unsuccessful start up tries the fan will be turned off for 40 seconds.

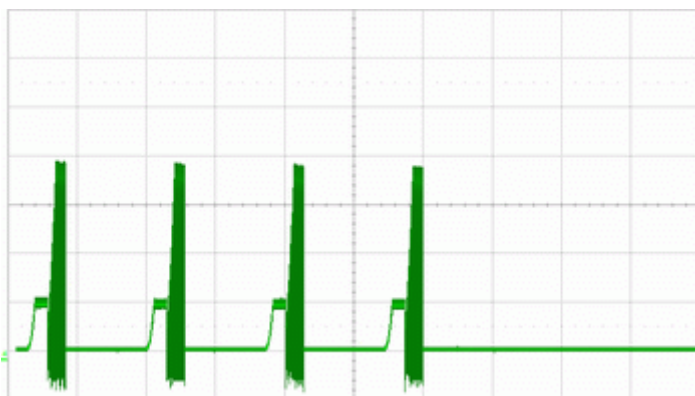

Locked rotor current at 24 V; 0,5A/div; 10s/div

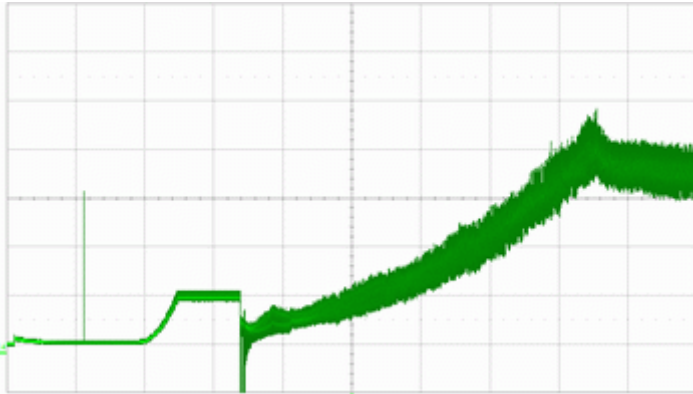

Start-up current at 24 V; 0,5A/div; 2s/div



Typical running current at 24 V; 0,5A/div; 2ms/div

Inrush current limiter:

This fan is equipped with an inrush current limiter to reduce the charging current of the internal capacitor. By this circuit the fan gets a start-up delay of 2 s after connecting the supply voltage. Only a short peak current can be measured at the inrush by charging the small internal filter capacitors with approximately 6,6 μ F.

Data According ErP Directive/Installation / Efficiency category	A / static
Speed control	integrated
Specific ratio	1,00359
Target overall efficiency 2015	29,1 %
Overall efficiency	52,4 %
Efficiency grade	40
Power input	188 W
Speed	6.570 1/min

All values measured in optimum energy efficiency point.

3.5 Aerodynamics

Measurement conditions:

Measured with a double chamber intake rig acc. to DIN EN ISO 5801.
 Normal air density = 1,2 kg/m³; Temperature 23°C +/- 3°C;
 In the intake and outlet area should not be any solid obstruction within 0,5 m.
 The information is only valid under the specified test conditions and may be changed by the installation conditions. If there are deviations from the standard test conditions, the characteristic values must be checked under the installed conditions. Power consumption of the fan motor when operating at normal voltage is shown. Depending on the operating conditions of the application, the power input may be higher.

a.) Operation condition:

6.500 1/min at free air flow	U Contr. 10 V		
------------------------------	---------------	--	--

Max. free-air flow ($\Delta p = 0 / \dot{V} = \text{max.}$)	1.230 m ³ /h	
Max. static pressure ($\Delta p = \text{max.} / \dot{V} = 0$)	1.180 Pa	

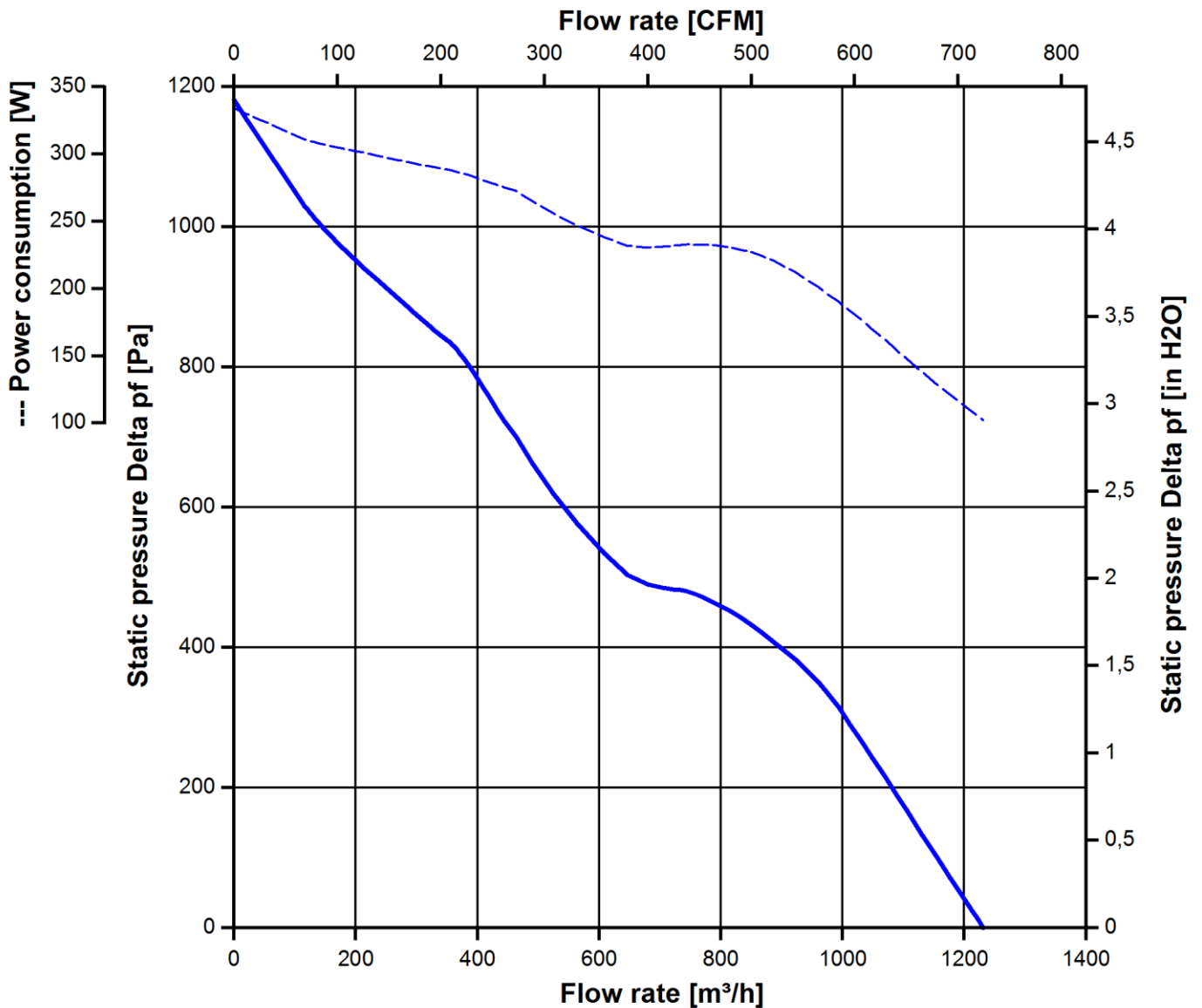

3.6 Sound Data

Measurement conditions: Sound pressure level: 1 meter distance between microphone and the air intake.
 Sound power level: Acc. to DIN 45635 part 38 (ISO 10302)
 Measured in a semianchoic chamber with a background noise level of $L_p(A) < 5 \text{ dB(A)}$
 For further measurement conditions see section 3.5

a.) Operation condition:

6.500 1/min at free air flow	U Contr. 10 V		
------------------------------	---------------	--	--

Optimal operating point	1.200 m ³ /h @ 44 Pa	
Sound power level at the optimal operating point	8,2 bel(A)	
Sound pressure level at free air flow, measured in rubber bands	74,0 dB(A)	

4 Environment

4.1 General

Min. permitted ambient temperature TU min.	-20 °C	
Max. permitted ambient temperature TU max.	65 °C	
Min. permitted storage temperature TL min.	-40 °C	
Max. permitted storage temperature TL max.	80 °C	

4.2 Climatic Requirements

Humidity requirements	humid heat, cyclic; according to DIN EN 60068-2-30, 6 cycle	
Water exposure	None	
Dust requirements	Dust check; according to DIN EN 60068-2-68, 6g/m ² d, 1 day	
Salt fog requirements	None	

Permitted application area:

The product is for the use in sheltered rooms with limited controlled temperature. Occasionally condensed water is allowed. Direct exposure to water must be avoided. Saline ambient conditions must be avoided.

Pollution degree 2 (according DIN EN 60664-1)

It occurs only non-conductive pollution. Occassionally, temporary conductivity caused by condensation occurs.

4.3 Mechanical Requirements

severity level	Vibration (sinusoidal)	
2 G	Vibration (sinusoidal) in use IEC 60068-2-6 Displacement / frequency range Acceleration / frequency range Sweep rate Sweep cycles Duration Axes of vibration	Vibration (sinusoidal) 0,15 mm / 10-58, 58-10 Hz 2 G / 58-500-58 Hz 1 Oct./min 10 2 hrs. 3

severity level	stationary use		
1	storage / transportation	Random vibration not in use IEC 60068-2-64 Frequency range / ASD G_{RMS} Axes of vibration Test duration	Random vibration 5 - 20 Hz : $1,0 \text{ m}^2 / \text{s}^3$ 20 - 500 Hz : - 3 dB / Oct 0,91 G 3 3 x 30 min
	storage / transportation	Bump not in use IEC 60068-2-29 Shock spectrum Acceleration Duration Number of bumps (+X, -X, -Y, +Y, -Z, +Z) Total bumps	Bump half sine 18 G 6 ms 100 in each direction 600
	stationary use	Random vibration in use IEC 60068-2-64 Frequency range / ASD G_{RMS} Axes of vibration Test duration	Random vibration 5 - 10 Hz : +6 dB / Oct 10 - 50 Hz : $1,0 \text{ m}^2 / \text{s}^3$ 50 - 200 Hz : - 6 dB / Oct 0,65 G 3 3 x 30 min
	stationary use	Bump in use IEC 60068-2-29 Shock spectrum Acceleration Duration Number of bumps (+X, -X, -Y, +Y, -Z, +Z) Total bumps	Bump half sine 5 G 11 ms 100 in each direction 600

severity level	Railroad application	
1 IEC 61373 Category 1 Class B	Random vibration in use IEC 60068-2-64 Frequency range / ASD G_{RMS} Axes of vibration Test duration	Random vibration 5 - 10 Hz : +6 dB / Oct 10 - 50 Hz : $1,0 \text{ m}^2 / \text{s}^3$ 50 - 200 Hz : - 6 dB / Oct 0,65 G 3 3 x 30 min
	Shock in use IEC 60068-2-27 Shock spectrum Acceleration Duration Number of bumps (+X, -X, -Y, +Y, -Z, +Z) Total bumps	Shock half sine 7 G 18 ms 10 in each direction 60

5 Safety

5.1 Electrical Safety

Dielectric strength DIN EN 60950 (VDE 0805) and DIN EN 60335 (VDE 0700) A.) Type test Measuring conditions: After 48h of storage at 95% R.H. and 25°C. No arcing or breakdown is allowed! All connections together to ground. B.) Routine test Measuring conditions: At indoor climate. No arcing or breakdown is allowed! All connections together to ground.	1000 VAC / 1 Min. 1000 VAC / 1 Sec.	
Isolation resistance Measuring conditions: After 48h of storage at 95% R.H. and 25°C measured with U=500 VDC for 1 min.	RI > 10 MOhm	
Clearance / creepage distance	1,0 mm / 1,5 mm	
Protection class	I	

5.2 Approval Tests

CE	EC Declaration of Conformity	Yes
EAC	Eurasian Conformity	Yes
UL	Underwriters Laboratories	Yes / UL audited by CSA according to UL507, Electric Fans
VDE	Association for Electrical, Electronic and Information Technologies	Yes / Approval acc. to EN 60950 (VDE 0805) - Information technology equipment
CSA	Canadian Standards Association	Yes / C22.2 No. 113 Fans and Ventilators
CCC	China Compulsory Certification	Yes / GB 12350 Safety Requirements for small Power Motors

6 Reliability

6.1 General

Life expectancy L10 at TU = 40 °C	70.000 h	
Life expectancy L10 at TU max.	40.000 h	
Life expectancy L10 acc. to IPC 9591 at TU = 40 °C	117.500 h	

Copying of this document, and giving it, others and the use or communication of the contents thereof, are forbidden without express authority. Offenders are liable to the payment of damages. All rights are reserved in the event of the grant of a patent or the registration of a utility model or design.

Steuerrecht nach DIN ISO 16010 beachten / Refer to protection notice DIN ISO 16010

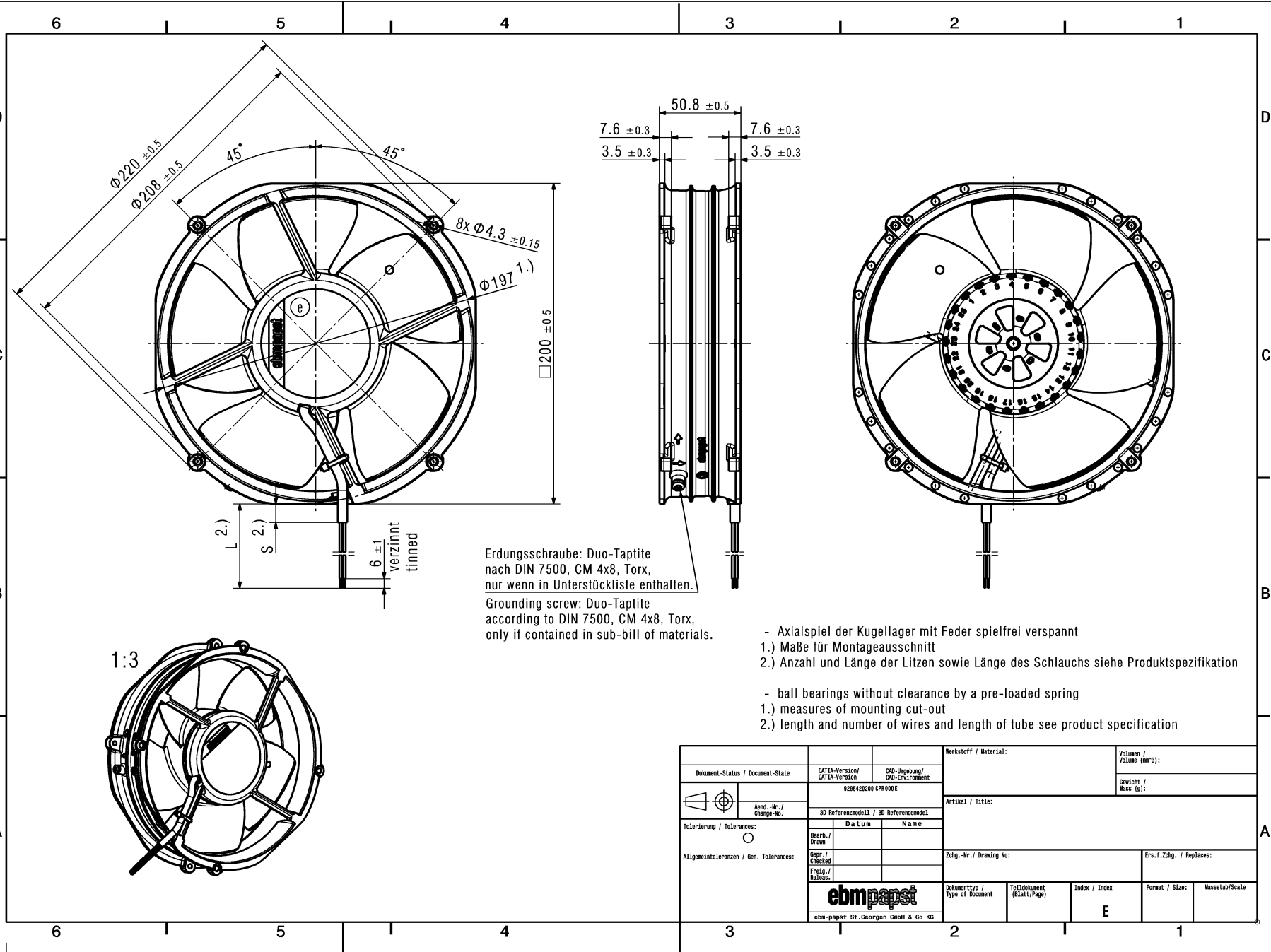

Erdungsschraube: Duo-Tapitite nach DIN 7500, CM 4x8, Torx, nur wenn in Unterstückliste enthalten.
 Grounding screw: Duo-Tapitite according to DIN 7500, CM 4x8, Torx, only if contained in sub-bill of materials.

- Axialspiel der Kugellager mit Feder spielfrei verspannt
1.) Maße für Montageausschnitt
- ball bearings without clearance by a pre-loaded spring
1.) measures of mounting cut-out
- 2.) Anzahl und Länge der Litzen sowie Länge des Schlauchs siehe Produktspezifikation
2.) length and number of wires and length of tube see product specification

Dokument-Status / Document-State		CATIA-Version/ CATIA-Versions		CAD-Umgebung/ CAD-Environment		Werkstoff / Material:		Volumen / Volume (cm ³):	
		9295420200		CPR000E				Gewicht / Mass (g):	
Aend.-Nr. / Change-No.		SD-Referenzmodell / SD-Referenzmodell		Artikel / Title:					
Tolerierung / Tolerances:		Datum		Name		Zchg.-Nr. / Drawing No:		Ers.-f. Zchg. / Replaces:	
Allgemeintoleranzen / Gen. Tolerances:		Bearb. / Drawn							
		Gepr. / Checked							
		Freig. / Released							
		ebmpapst		Dokumenttyp / Type of Document		Teildokument (Blatt/Page)		Index / Index	
				Format / Size:		Maßstab/Scale			
		ebm-papst St. Georgen GmbH & Co KG						E	