

ASIA PACIFIC SHENGRUI LIMITED

Phone +00852 56261528

info@apacfan.com

www.apacfan.com



Nominal data

Type	S3G710-AO81-01	
Motor	M3G112-IA	
Phase		3~
Nominal voltage	VAC	400
Nominal voltage range	VAC	380 .. 480
Frequency	Hz	50/60
Type of data definition		ml
Speed	min ⁻¹	900
Power input	W	930
Current draw	A	1.5
Max. back pressure	Pa	125
Min. ambient temperature	°C	-25
Max. ambient temperature	°C	60

ml = Max. load · me = Max. efficiency · fa = Running at free air · cs = Customer specs · cu = Customer unit
Subject to alterations

Data according to ErP directive

Installation category	A
Efficiency category	Static
Variable speed drive	Yes
Specific ratio*	1.00

* Specific ratio = $1 + p_b / 100\,000\text{ Pa}$

		Actual	Request 2013	Request 2015
Overall efficiency η_{es}	%	41.9	29.3	33.3
Efficiency grade N		48.6	36	40
Power input P_{ed}	kW	0.86		
Air flow q_v	m ³ /h	11370		
Pressure increase p_{fs}	Pa	105		
Speed n	min ⁻¹	905		

Data definition with optimum efficiency. LU-117117
The ErP data is determined using a motor-impeller combination in a standardised measurement configuration.



Technical features

Mass	19.3 kg
Size	710 mm
Surface of rotor	Coated in black
Material of electronics housing	Die-cast aluminium
Material of blades	Aluminium sheet insert, sprayed with PP plastic
Material of guard grille	Steel, coated in black plastic (RAL9005)
Number of blades	5
Blade angle	0°
Direction of air flow	"V"
Direction of rotation	Counter-clockwise, seen on rotor
Type of protection	IP 54
Insulation class	"B"
Humidity class	F4-1
Max. permissible ambient motor temp. (transp./ storage)	Max. +80 °C
Min. permissible ambient motor temp. (transp./storage)	Min. -40 °C
Mounting position	Shaft horizontal or rotor on bottom; rotor on top on request
Condensate discharge holes	Rotor-side
Operation mode	S1
Motor bearing	Ball bearing
Technical features	<ul style="list-style-type: none"> - Output 10 VDC, max. 10 mA - Alarm relay - Integrated PID controller - Motor current limit - PFC, passive - Soft start - Control input 0-10 VDC / PWM - Control interface with SELV potential safely disconnected from the mains - Over-temperature protected electronics / motor - Line undervoltage / phase failure detection
EMC interference immunity	Acc. to EN 61000-6-2 (industrial environment)
EMC harmonics	Acc. to EN 61000-3-2/3
EMC interference emission	Acc. to EN 61000-6-4 (industrial environment)
Touch current acc. IEC 60990 (measuring network Fig. 4, TN system)	<= 3.5 mA
Motor protection	Thermal overload protector (TOP) wired internally
Cable exit	Variable
Protection class	I (if protective earth is connected by customer)
Product conforming to standard	EN 61800-5-1; CE
Approval	EAC

EC axial fan - HyBlade®

sickled blades (S series)

with guard grille for short nozzle

Product drawing

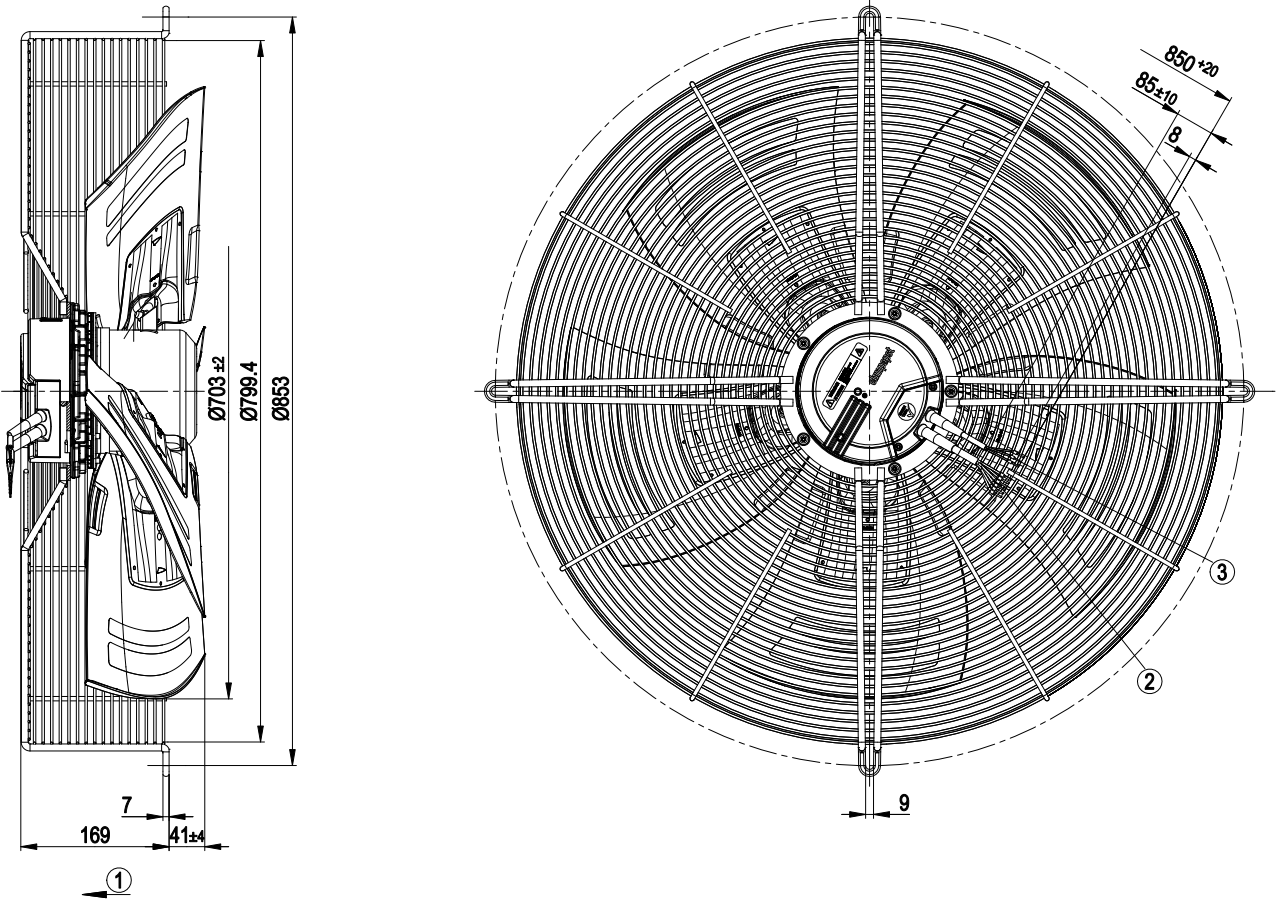

1	Direction of air flow "V"
2	Connection line PVC AWG18, 6x crimped core-end sleeves
3	Connection line PVC AWG22, 3x crimped core-end sleeves



EC axial fan - HyBlade®

sickled blades (S series)
with guard grille for short nozzle

Connection screen

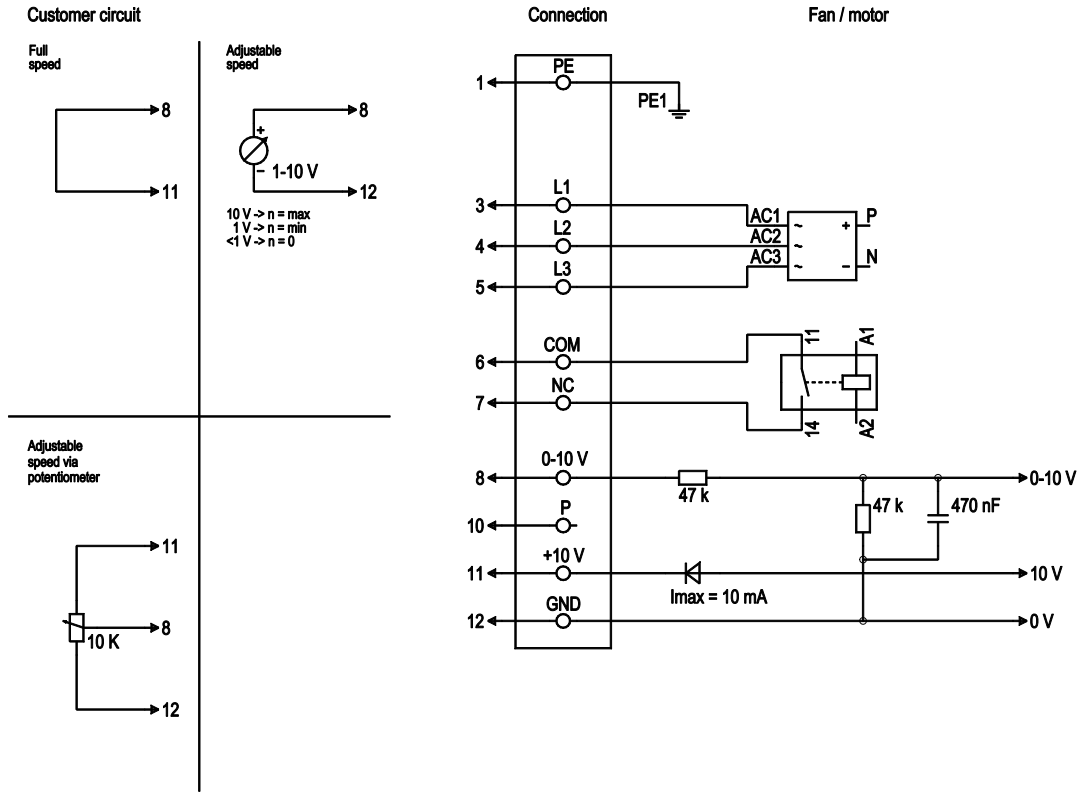

No.	Conn.	Designation	Colour	Function / assignment
1	1	PE	green/yellow	Ground wire
1	3	L1	black	Supply voltage, 50/60 Hz
1	4	L2	black	Supply voltage, 50/60 Hz
1	5	L3	black	Supply voltage, 50/60 Hz
1	6	COM	white 1	Floating status message contact, normally closed connection (2 A, max. 250 VAC, min. 10 mA, AC1)
1	7	NC	white 2	Floating status message contact, normally closed connection
2	8	0-10 V	yellow	Control input, set value 0-10 VDC, impedance 100 kΩ, SELV
2	10	P	orange	Do not use
2	11	+10 V	red	Voltage output 10 VDC (+/-3%), max. 10 mA, supply voltage for external devices (e.g. potentiometer), SELV
2	12	GND	blue	Reference mass for control interface, SELV



Charts: Air flow 50 Hz

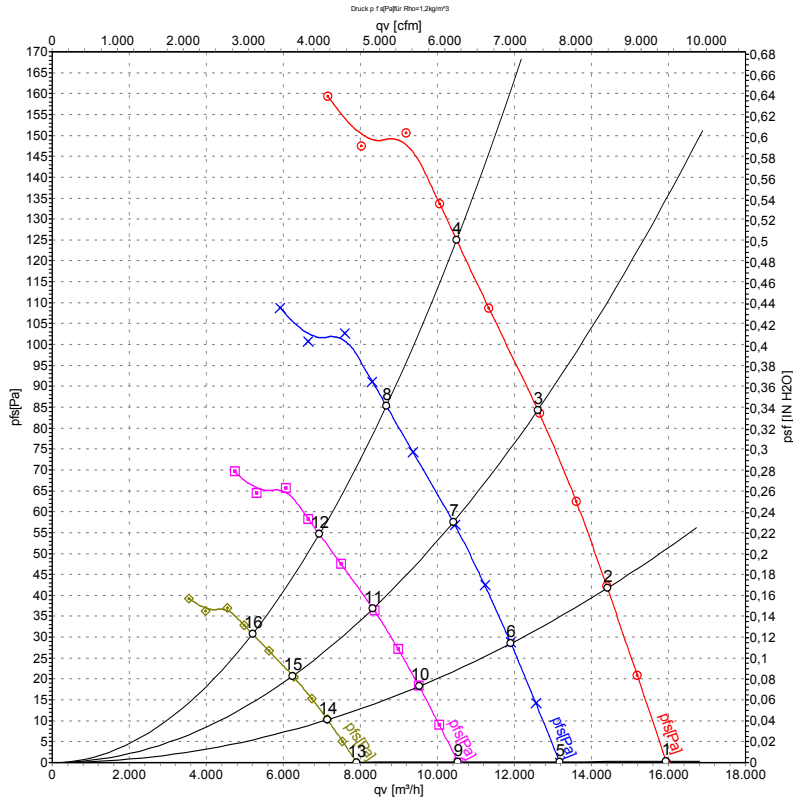

Measurement: LU-123826

Air performance measured as per ISO 5801 Installation category A. For detailed information on the measuring set-up, please contact ebmpapst. Suction-side noise levels: LwA measured as per ISO 13347 / LpA measured with 1m distance to fan axis. The values given are valid under the measuring conditions mentioned above and may vary according to the actual installation situation. With any deviation from the standard set-up, the specific values have to be checked and reviewed with the unit installed.

Measured values

	U	f	n	P _{ed}	I	Lp _{Ain}	LwA _{in}	LwA _{out}	qv	p _{fs}
	V	Hz	min ⁻¹	W	A	dB(A)	dB(A)	dB(A)	m ³ /h	Pa
1	400	50	900	602	1.02	64	70	71	15940	0
2	400	50	900	718	1.17	63	69	69	14420	42
3	400	50	900	827	1.30	63	70	70	12610	85
4	400	50	900	930	1.50	69	75	75	10500	125
5	400	50	750	340	0.58	60	66	67	13170	0
6	400	50	750	405	0.66	59	65	65	11910	29
7	400	50	750	465	0.73	59	65	66	10410	58
8	400	50	750	523	0.82	65	71	71	8670	85
9	400	50	600	174	0.30	55	61	62	10540	0
10	400	50	600	208	0.34	54	60	60	9530	18
11	400	50	600	238	0.38	54	61	61	8330	37
12	400	50	600	268	0.42	60	66	66	6940	55
13	400	50	450	73	0.12	49	55	55	7905	0
14	400	50	450	88	0.14	47	54	54	7145	10
15	400	50	450	100	0.16	48	54	55	6245	21
16	400	50	450	113	0.18	54	60	60	5205	31

U = Supply voltage · f = Frequency · n = Speed · P_{ed} = Power input · I = Current draw · Lp_{Ain} = Sound pressure level inlet side · LwA_{in} = Sound power level inlet side · LwA_{out} = Sound power level outlet side
 qv = Air flow · p_{fs} = Pressure increase

