

R3G355-RP23-33

EC centrifugal fan - RadiCal

backward-curved, single-intake



ASIA PACIFIC SHENGRUI LIMITED

Phone +00852 56261528

info@apacfan.com

www.apacfan.com

Nominal data

Type	R3G355-RP23-33	
Motor	M3G084-FA	
Nominal voltage	VDC	48
Nominal voltage range	VDC	36 .. 57
Method of obtaining data		fa
Speed (rpm)	min ⁻¹	1760
Power consumption	W	290
Current draw	A	6.1
Min. ambient temperature	°C	-25
Max. ambient temperature	°C	50

ml = Max. load · me = Max. efficiency · fa = Free air · cs = Customer specification · ce = Customer equipment
Subject to change

Data according to Commission Regulation (EU) 327/2011 (EN 17166)

		Actual	Req. 2015			
01 Overall efficiency η_{es}	%	68.8	47.1	09 Power consumption P_e	kW	0.38
02 Measurement category		A		09 Air flow q_v	m ³ /h	2405
03 Efficiency category		Static		09 Pressure increase p_{fs}	Pa	355
04 Efficiency grade N		83.7	62	10 Speed (rpm) n	min ⁻¹	1690
05 Variable speed drive		Yes		11 Specific ratio*		1.00

Data obtained at optimum efficiency level.

* Specific ratio = $1 + p_{fs} / 100\,000\text{ Pa}$

LU-155134

The efficiency values displayed for achieving conformity with the Ecodesign Regulation EU 327/2011 has been reached with defined air duct components (e.g. inlet rings).
The dimensions must be requested from ebmpapst. If other air conduction geometries are used on the installation side, the ebmpapst evaluation loses its validity/the conformity must be confirmed again.
The product does not fall within the scope of Regulation (EU) 2019/1781 due to the exception specified in Article 2 (2a) (motors completely integrated into a product).



Technical description

Weight	4.86 kg
Size	355 mm
Motor size	84
Rotor surface	Painted black
Electronics housing material	Die-cast aluminum, painted black
Impeller material	PP plastic
Number of blades	6
Direction of rotation	Clockwise, viewed toward rotor
Degree of protection	IP42
Insulation class	"B"
Moisture (F) / Environmental (H) protection class	H1
Max. permitted ambient temp. for motor (transport/storage)	+80 °C
Min. permitted ambient temp. for motor (transport/storage)	-40 °C
Installation position	Any
Condensation drainage holes	None
Mode	S1
Motor bearing	Ball bearing
Technical features	<ul style="list-style-type: none"> - Fault output (open collector) - Motor current limitation - Soft start - Control input 0-10 VDC / PWM - Thermal overload protection for motor - Reverse polarity protection
Electrical hookup	Connector with cable
Motor protection	Thermal overload protector (TOP) internally connected
With cable	Variable
Protection class assignment	<p>Built-in component, protection class is based on the intended installation. This component for installation may have several local protection classes. This information relates to this component's basic design.</p> <p>The final protection class is based on the component's intended installation and connection.</p>
Conformity with standards	EN 61800-5-1; CE; UKCA
Approval	UL 1004-1; EAC; CSA C22.2 No. 100

Product drawing

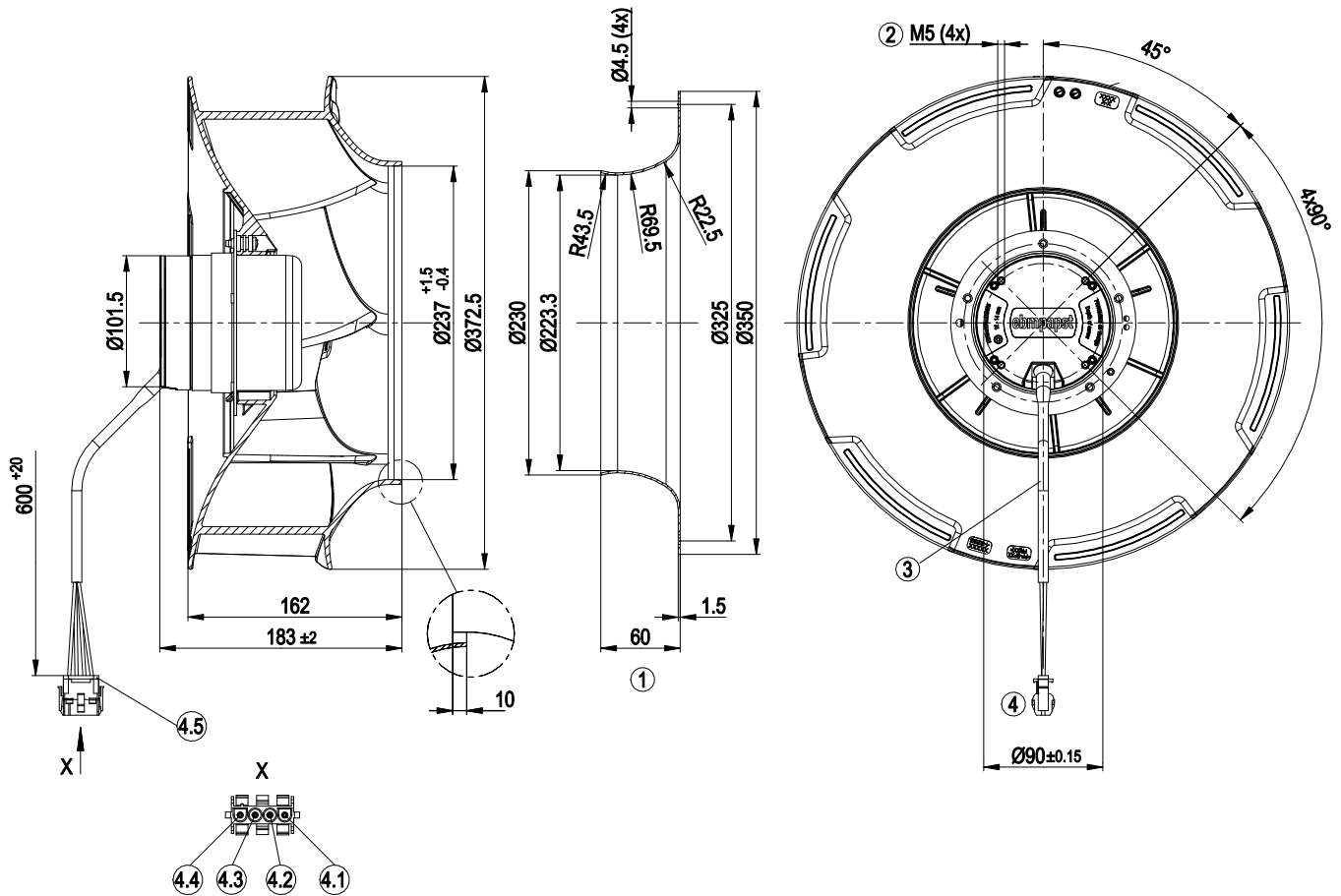

1	Accessory part: inlet ring 35500-2-4013 not included in scope of delivery
2	Max. clearance for screw 14 mm
3	Cable PVC AWG16, 4x crimped socket 926882-1
4	4-pole connector housing tyco 350780-1
4.1	UN +48 VDC (red)
4.2	GND (blue)
4.3	PWM/LIN (yellow)
4.4	Tach (white)
4.5	Seal AMP 794 274-1

Connection diagram

Customer circuit
Application notes for various control options

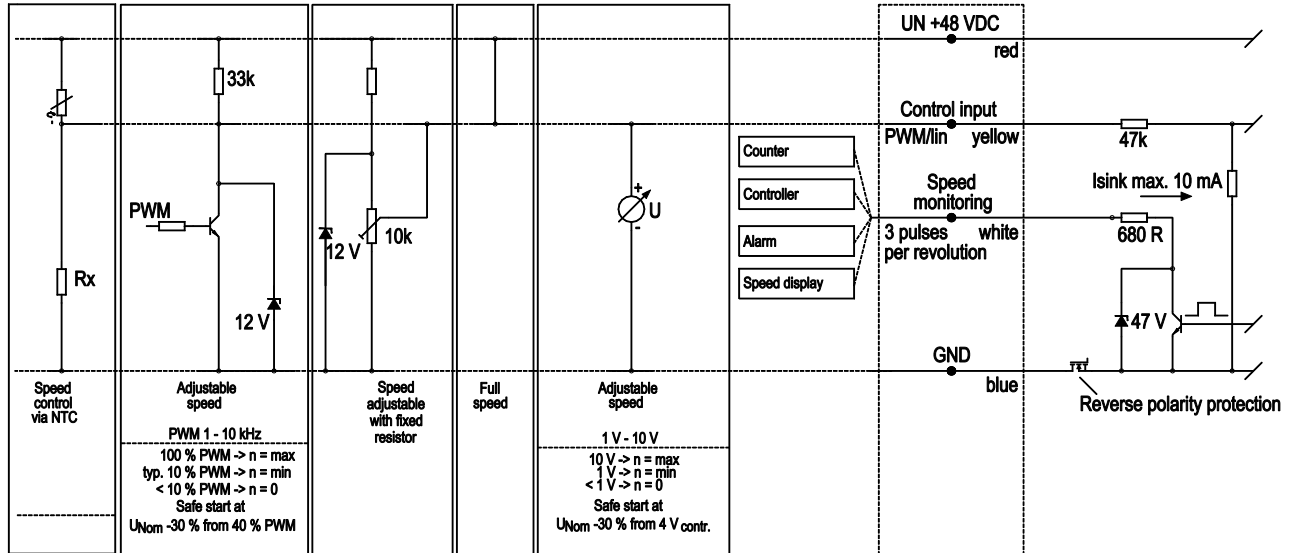

Curves: Air performance

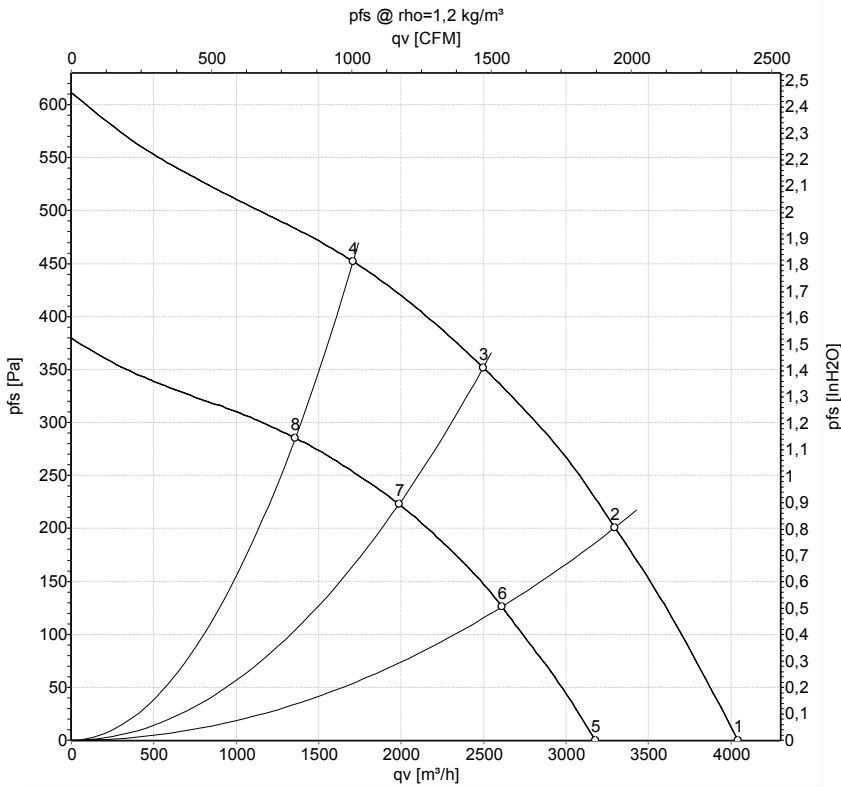

Measurement: LU-155134-1
Measurement: LU-145471-1

Air performance measured according to ISO 5801 installation category A. For detailed information on the measurement setup, contact ebm-papst. Intake sound level: Sound power level according to ISO 13347 / sound pressure level measured at 1 m distance from fan axis. The values given are valid under the specified measuring conditions and may vary due to conditions of installation. For deviations from the standard configuration, the parameters have to be checked on the installed unit.

Measured values

	U	n	P _{ed}	I	q _v	p _{fs}	q _v	p _{fs}
	V	min ⁻¹	W	A	m ³ /h	Pa	cfm	in. wg
1	48-57	1760	290	6.10*	4045	0	2380	0.00
2	48-57	1710	358	7.60*	3295	200	1940	0.80
3	48-57	1690	383	8.10*	2495	350	1470	1.41
4	48-57	1705	368	7.80*	1710	450	1005	1.81
5	36	1390	147	4.11	3180	0	1870	0.00
6	36	1360	175	4.88	2610	126	1535	0.51
7	36	1345	192	5.35	1985	224	1170	0.90
8	36	1355	183	5.12	1360	285	800	1.14

U = Voltage · n = Speed (rpm) · P_{ed} = Power consumption · I = Current draw · * = Current measured at nominal voltage · q_v = Air flow · p_{fs} = Pressure increase

