

## ASIA PACIFIC SHENGRUI LIMITED

Phone +00852 56261528

info@apacfan.com

www.apacfan.com

## Nominal data

Type	R2E180-BD52-07		
Motor	M2E052-CA		
Phase		1~	1~
Nominal voltage	VAC	230	230
Frequency	Hz	50	60
Method of obtaining data		fa	fa
Valid for approval/standard		CE	CE
Speed (rpm)	min <sup>-1</sup>	2300	2300
Power consumption	W	52	65
Current draw	A	0.24	0.3
Capacitor	μF	1.5	1.5
Capacitor voltage	VDB	400	400
Capacitor standard		S0 (CE)	S0 (CE)
Min. back pressure	Pa	0	0
Min. back pressure	in. wg	0	0
Min. ambient temperature	°C	-25	-25
Max. ambient temperature	°C	70	65

ml = Max. load · me = Max. efficiency · fa = Free air · cs = Customer specification · ce = Customer equipment  
Subject to change



### Technical description

<b>Weight</b>	1 kg
<b>Size</b>	180 mm
<b>Motor size</b>	52
<b>Rotor surface</b>	Unpainted
<b>Impeller material</b>	Sheet steel, rust-resistant
<b>Number of blades</b>	6
<b>Direction of rotation</b>	Clockwise, viewed toward rotor
<b>Degree of protection</b>	IP00
<b>Insulation class</b>	"F"
<b>Moisture (F) / Environmental (H) protection class</b>	H0 - dry environment
<b>Max. permitted ambient temp. for motor (transport/storage)</b>	+ 80 °C
<b>Min. permitted ambient temp. for motor (transport/storage)</b>	- 40 °C
<b>Installation position</b>	Any
<b>Condensation drainage holes</b>	None
<b>Mode</b>	S1
<b>Motor bearing</b>	Ball bearing
<b>Touch current according to IEC 60990 (measuring circuit Fig. 4, TN system)</b>	< 0.75 mA
<b>Electrical hookup</b>	Connector with cable
<b>Motor protection</b>	Thermal overload protector (TOP) internally connected
<b>With cable</b>	Lateral
<b>Protection class</b>	I (if the protective earth is connected by the customer to the marked PE connection point)
<b>Conformity with standards</b>	EN 60335-1; CE

## Product drawing

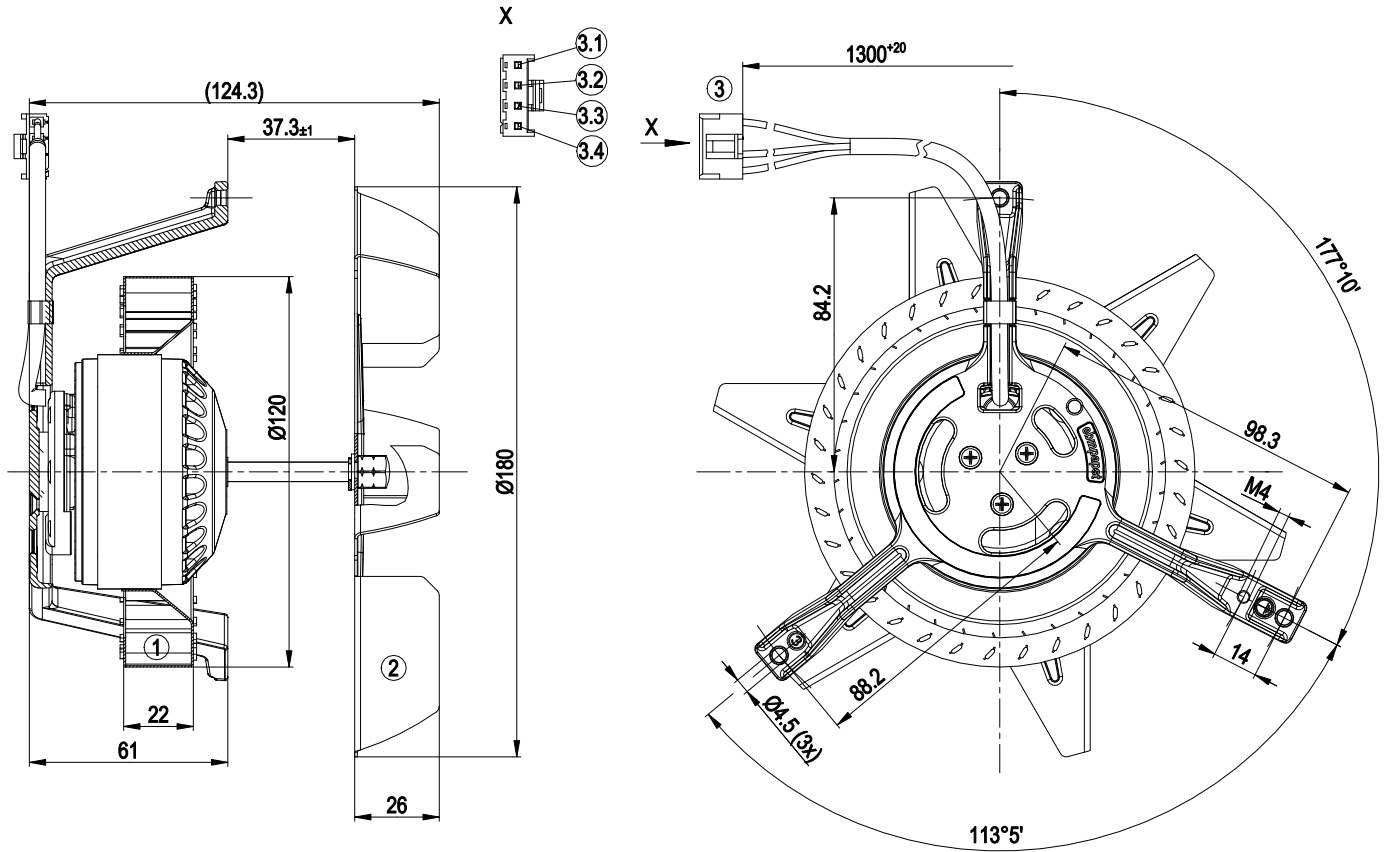

1	Centrifugal fan impeller (sheet steel, galvanized)
2	Centrifugal fan impeller (sheet steel, stainless)
3	Cable PFA AWG20, 4-pole connector housing JST NVR-04, 3x crimped socket JST SVH-21-P1.1
3.1	brown
3.2	free
3.3	blue
3.4	black

## Connection diagram

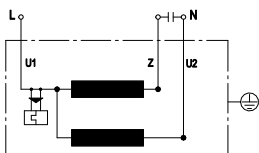

U1	blue	Z	brown	U2	black
----	------	---	-------	----	-------

## Curves: Air performance 50 Hz

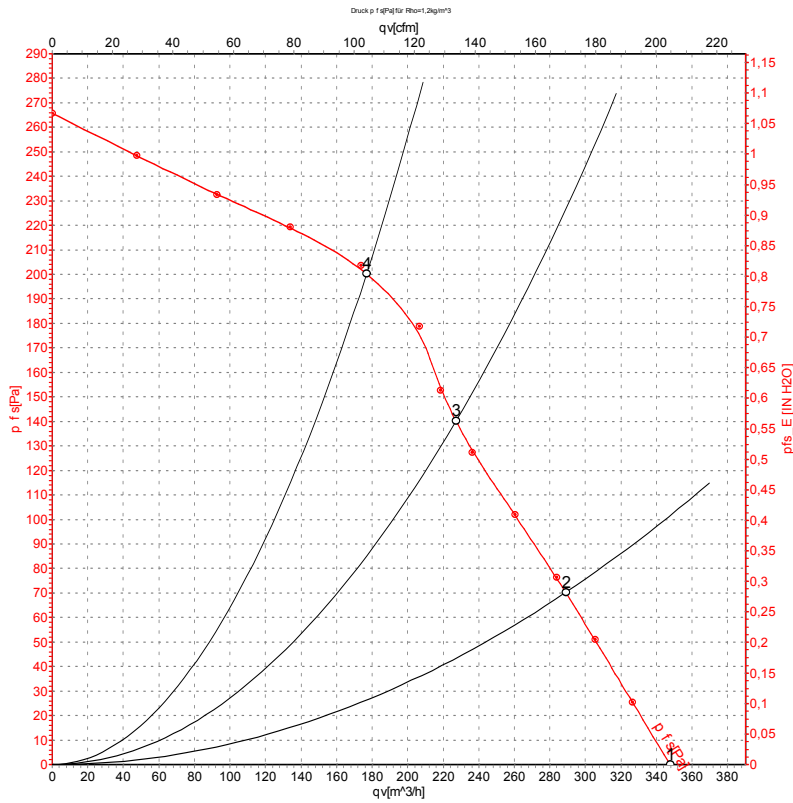

Measurement: LU-37375-1

Air performance measured according to ISO 5801 installation category A. For detailed information on the measurement setup, contact ebm-papst. Intake sound level: Sound power level according to ISO 13347 / sound pressure level measured at 1 m distance from fan axis. The values given are valid under the specified measuring conditions and may vary due to conditions of installation. For deviations from the standard configuration, the parameters have to be checked on the installed unit.

## Measured values

	U	f	n	P <sub>e</sub>	I	q <sub>V</sub>	p <sub>fs</sub>	q <sub>V</sub>	p <sub>fs</sub>
	V	Hz	min <sup>-1</sup>	W	A	m <sup>3</sup> /h	Pa	cfm	in. wg
1	230	50	2300	52	0.24	350	0	205	0.00
2	230	50	2300	52	0.23	290	70	170	0.28
3	230	50	2320	51	0.22	225	140	135	0.56
4	230	50	2445	48	0.21	175	200	105	0.80

U = Voltage · f = Frequency · n = Speed (rpm) · P<sub>e</sub> = Power consumption · I = Current draw · q<sub>V</sub> = Air flow · p<sub>fs</sub> = Pressure increase



## Curves: Air performance 60 Hz

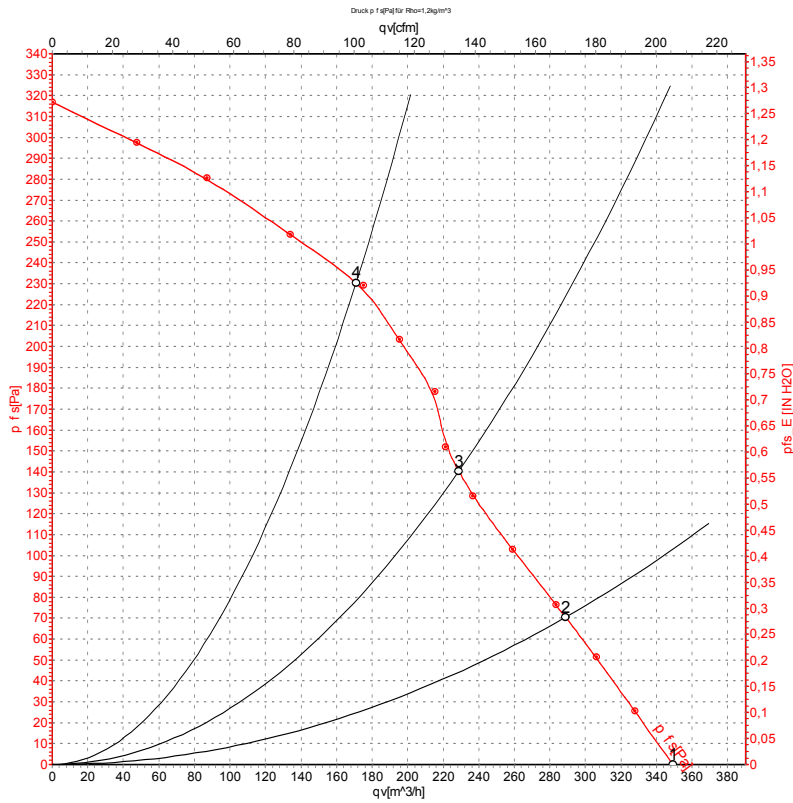

Measurement: LU-37376-1

Air performance measured according to ISO 5801 installation category A. For detailed information on the measurement setup, contact ebm-papst. Intake sound level: Sound power level according to ISO 13347 / sound pressure level measured at 1 m distance from fan axis. The values given are valid under the specified measuring conditions and may vary due to conditions of installation. For deviations from the standard configuration, the parameters have to be checked on the installed unit.

## Measured values

	U	f	n	P <sub>e</sub>	I	q <sub>V</sub>	P <sub>fs</sub>	q <sub>V</sub>	P <sub>fs</sub>
	V	Hz	min <sup>-1</sup>	W	A	m³/h	Pa	cfm	in. wg
1	230	60	2300	65	0.30	350	0	205	0.00
2	230	60	2295	65	0.28	290	70	170	0.28
3	230	60	2330	64	0.28	230	140	135	0.56
4	230	60	2610	60	0.26	170	230	100	0.92

U = Voltage · f = Frequency · n = Speed (rpm) · P<sub>e</sub> = Power consumption · I = Current draw · q<sub>V</sub> = Air flow · P<sub>fs</sub> = Pressure increase

