

K3G225-RE07-03

EC centrifugal module - RadiCal®

backward curved
with housing

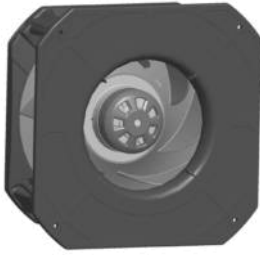

ASIA PACIFIC SHENGRUI LIMITED

Phone +00852 56261528

info@apacfan.com

www.apacfan.com



Nominal data

Type	K3G225-RE07-03	
Motor	M3G055-DF	
Phase		1~
Nominal voltage	VAC	230
Nominal voltage range	VAC	200 .. 240
Frequency	Hz	50/60
Type of data definition		ml
Speed	min ⁻¹	2860
Power input	W	170
Current draw	A	1.4
Min. ambient temperature	°C	-25
Max. ambient temperature	°C	60

ml = Max. load · me = Max. efficiency · fa = Running at free air · cs = Customer specs · cu = Customer unit
Subject to alterations

Data according to ErP directive

Installation category	A
Efficiency category	Static
Variable speed drive	Yes
Specific ratio*	1.00

* Specific ratio = $1 + p_{fs} / 100\,000\text{ Pa}$

		Actual	Request 2013	Request 2015
Overall efficiency η_{es}	%	61.7	39.1	43.1
Efficiency grade N		80.6	58	62
Power input P_{ed}	kW	0.16		
Air flow q_v	m ³ /h	705		
Pressure increase p_{fs}	Pa	458		
Speed n	min ⁻¹	2865		

Data definition with optimum efficiency. LU-127001
The ErP data is determined using a motor-impeller combination in a standardised measurement configuration.



backward curved
with housing

Technical features

Mass	2.5 kg
Size	225 mm
Surface of rotor	Thick layer passivated
Material of electronics housing	Die-cast aluminium
Material of impeller	PA plastic
Housing material	PA plastic
Number of blades	7
Direction of rotation	Clockwise, seen on rotor
Type of protection	IP 54
Insulation class	"B"
Max. permissible ambient motor temp. (transp./ storage)	+ 80 °C
Min. permissible ambient motor temp. (transp./storage)	- 40 °C
Mounting position	Any
Condensate discharge holes	None, open rotor
Operation mode	S1
Motor bearing	Ball bearing
Technical features	<ul style="list-style-type: none"> - Output 10 VDC, max. 1.1 mA - Tach output - Motor current limit - Soft start - Control input 0-10 VDC / PWM - Over-temperature protected electronics / motor - Line undervoltage detection
Touch current acc. IEC 60990 (measuring network Fig. 4, TN system)	<= 3.5 mA
Motor protection	Locked-rotor protection
Cable exit	Variable
Protection class	I (if protective earth is connected by customer)
Product conforming to standard	EN 60335-1
Approval	CCC; EAC

Product drawing

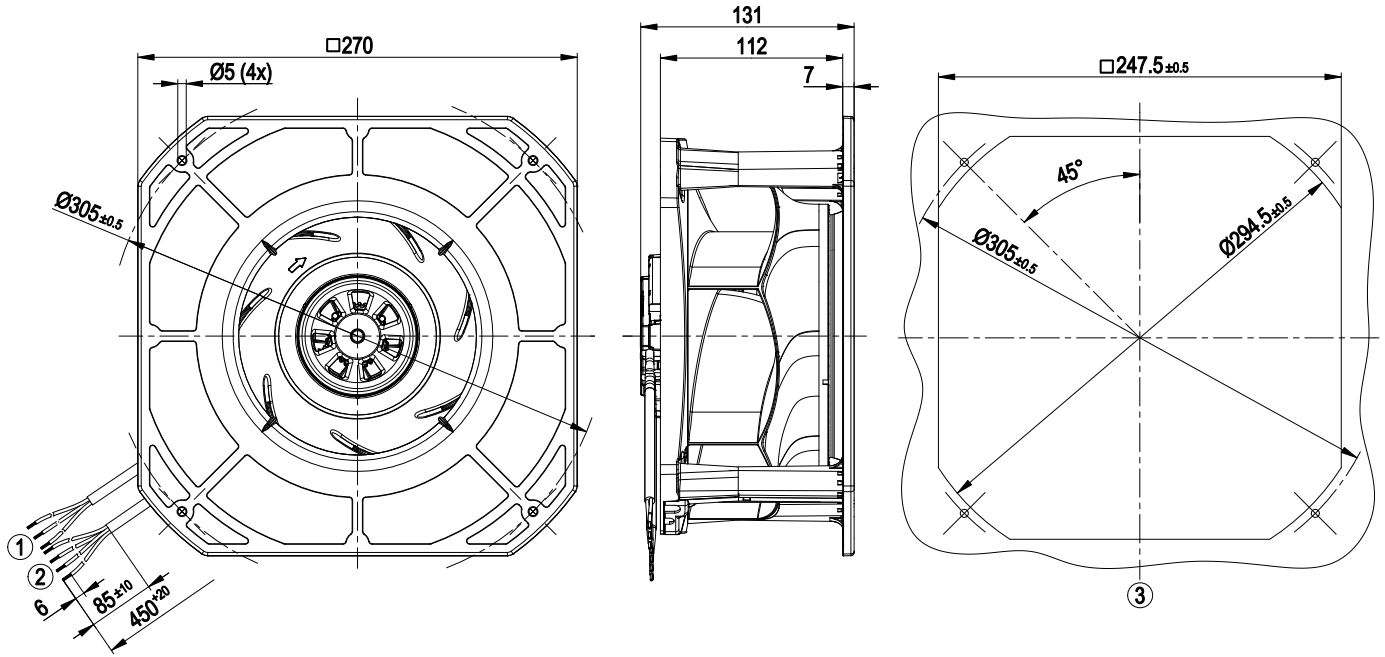

1	Connection line PVC AWG20, 3x lead tips crimped
2	Connection line PVC AWG22, 4x lead tips crimped
3	Mounting dimensions

backward curved
with housing

Connection screen

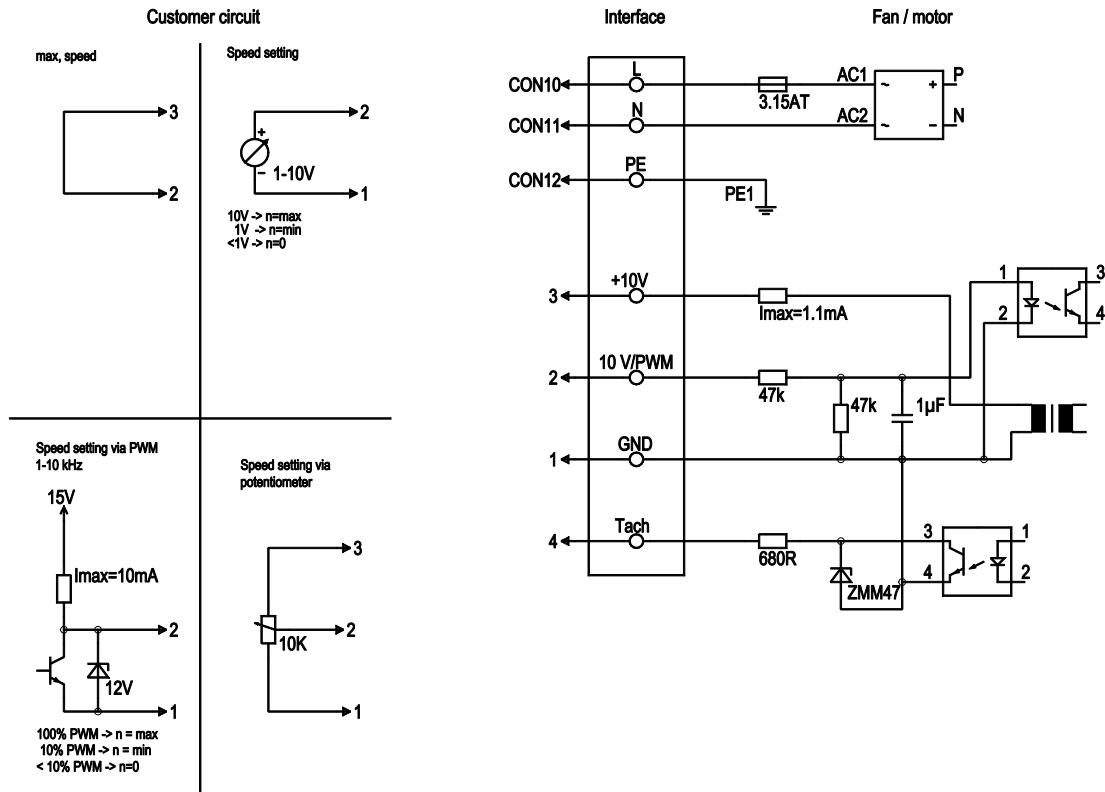

No.	Conn.	Designation	Colour	Function / assignment
	CON10	L	black	Power supply 230 VAC, 50-60 Hz, for voltage range refer to rating plate
	CON11	N	blue	Neutral conductor
	CON12	PE	green/yellow	Protective earth
	1	GND	blue	GND - Connection for control interface
	2	0- 10V PWM	yellow	Control input 0 - 10 V or PWM, electrically isolated
	3	10V/ max 1.1mA	red	Voltage output 10V/ 1.1mA, electrically isolated, not short-circuit-proof.
	4	Tach	white	Tach output: open collector, 1 pulse per revolution, electrically isolated

backward curved
with housing

Charts: Air flow 50 Hz

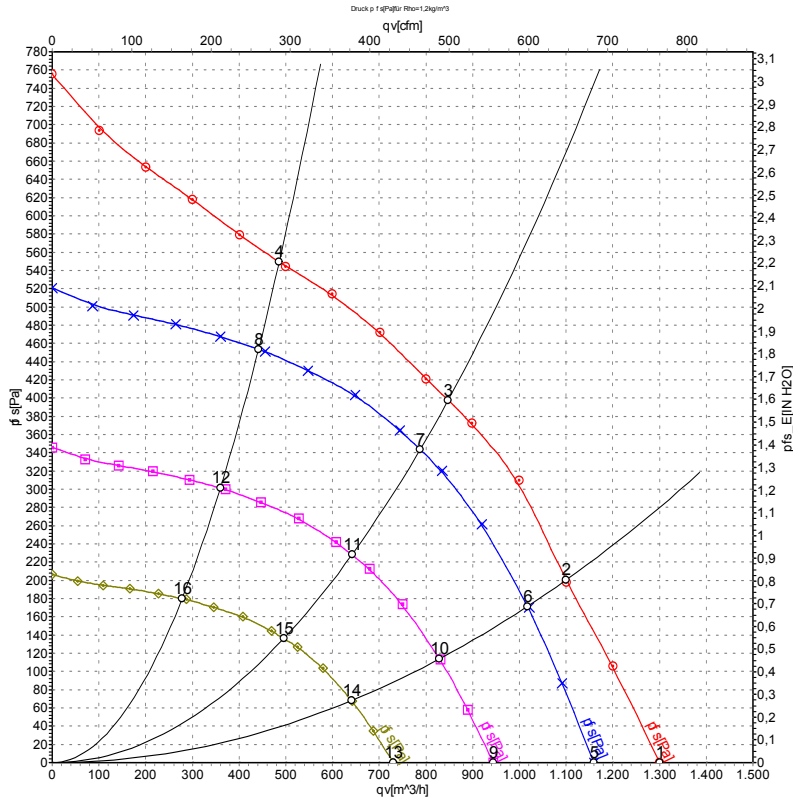

Air performance measured as per ISO 5801 Installation category A. For detailed information on the measuring set-up, please contact ebm-papst. Suction-side noise levels: LwA measured as per ISO 13347 / LpA measured with 1m distance to fan axis. The values given are valid under the measuring conditions mentioned above and may vary according to the actual installation situation. With any deviation from the standard set-up, the specific values have to be checked and reviewed with the unit installed.

Measured values

	U	f	n	P _{ed}	I	LpA _{in}	LwA _{in}	qv	p _{fs}
	V	Hz	min ⁻¹	W	A	dB(A)	dB(A)	m ³ /h	Pa
1	230	50	3030	151	1.25	70	78	1300	0
2	230	50	2910	168	1.40	66	74	1100	200
3	230	50	2860	170	1.40	60	68	850	400
4	230	50	2970	157	1.35	65	73	485	550
5	230	50	2700	107	0.89	68	76	1160	0
6	230	50	2700	134	1.11	65	72	1015	174
7	230	50	2700	135	1.15	59	67	790	344
8	230	50	2700	118	1.01	62	70	440	454
9	230	50	2200	58	0.48	63	70	945	0
10	230	50	2200	73	0.60	59	67	830	115
11	230	50	2200	73	0.62	54	62	640	228
12	230	50	2200	64	0.55	57	65	360	301
13	230	50	1700	27	0.22	56	64	730	0
14	230	50	1700	33	0.28	53	61	640	69
15	230	50	1700	34	0.29	48	56	495	136
16	230	50	1700	29	0.25	50	59	280	180

U = Supply voltage · f = Frequency · n = Speed · P_{ed} = Power input · I = Current draw · LpA_{in} = Sound pressure level inlet side · LwA_{in} = Sound power level inlet side · qv = Air flow
p_{fs} = Pressure increase

