

ASIA PACIFIC SHENGRUI LIMITED

Phone +00852 56261528

info@apacfan.com

www.apacfan.com

Nominal data

Type	R2E150-AE52-07		
Motor	M2E052-CA		
Phase		1~	1~
Nominal voltage	VAC	230	230
Frequency	Hz	50	60
Method of obtaining data		fa	fa
Valid for approval/standard		CE	CE
Speed (rpm)	min ⁻¹	2600	2950
Power consumption	W	42	53
Current draw	A	0.19	0.24
Capacitor	μF	1.5	1.5
Capacitor voltage	VDB	400	400
Capacitor standard		S0 (CE)	S0 (CE)
Min. back pressure	Pa	0	0
Min. back pressure	in. wg	0	0
Min. ambient temperature	°C	-25	-25
Max. ambient temperature	°C	60	65

ml = Max. load · me = Max. efficiency · fa = Free air · cs = Customer specification · ce = Customer equipment
Subject to change



Technical description

Weight	0.94 kg
Size	150 mm
Motor size	52
Rotor surface	Unpainted
Impeller material	Sheet steel, rust-resistant; sheet steel, galvanized
Number of blades	6
Direction of rotation	Clockwise, viewed toward rotor
Degree of protection	IP00
Insulation class	"F"
Moisture (F) / Environmental (H) protection class	H0 - dry environment
Max. permitted ambient temp. for motor (transport/storage)	+ 80 °C
Min. permitted ambient temp. for motor (transport/storage)	- 40 °C
Installation position	Any
Condensation drainage holes	None
Mode	S1
Motor bearing	Ball bearing
Touch current according to IEC 60990 (measuring circuit Fig. 4, TN system)	< 0.75 mA
Electrical hookup	Connector with cable
Motor protection	Thermal overload protector (TOP) internally connected
With cable	Lateral
Protection class	I (if the protective earth is connected by the customer to the marked PE connection point)
Conformity with standards	EN 60034-1; EN 60204-1; EN 60335-1; CE

Product drawing

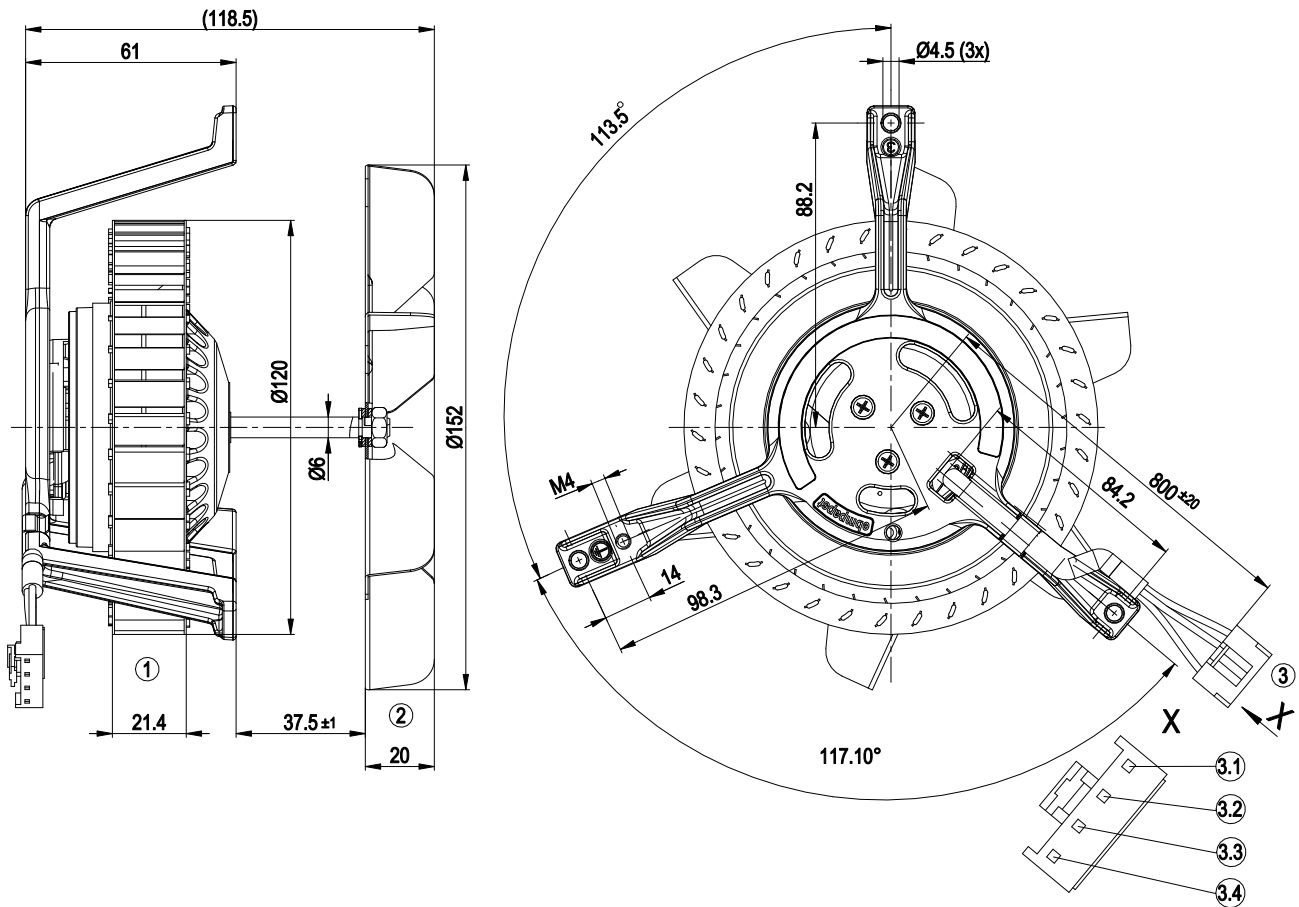

1	Centrifugal fan impeller (sheet steel, galvanized)
2	Centrifugal fan impeller (sheet steel, rust-resistant)
3	Cable PFA AWG20, 4-pole connector housing JST NVR-04, 3x crimped socket JST SVH-21-P1.1
3.1	N (black)
3.2	L (blue)
3.3	free
3.4	Z (brown)

Connection diagram

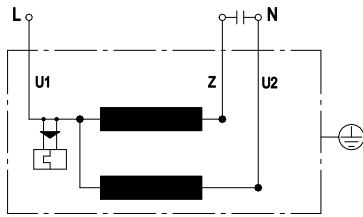

U1	blue	Z	brown	U2	black
----	------	---	-------	----	-------

Curves: Air performance 50 Hz

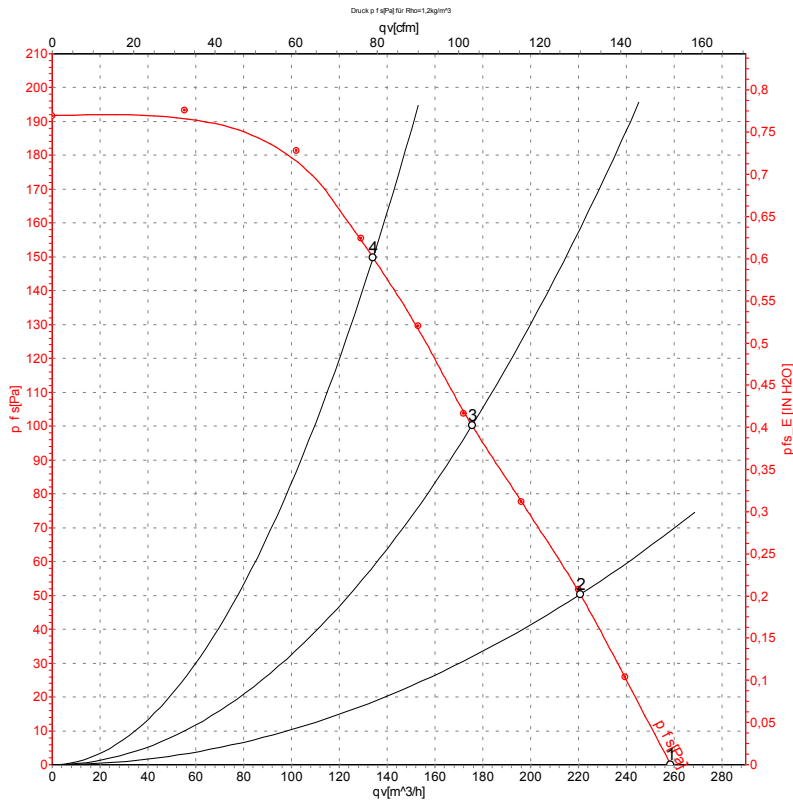

Measurement: LU-37284-1

Air performance measured according to ISO 5801 installation category A. For detailed information on the measurement setup, contact ebm-papst. Intake sound level: Sound power level according to ISO 13347 / sound pressure level measured at 1 m distance from fan axis. The values given are valid under the specified measuring conditions and may vary due to conditions of installation. For deviations from the standard configuration, the parameters have to be checked on the installed unit.

Measured values

	U	f	n	P _e	I	q _v	p _{fs}	q _v	p _{fs}
	V	Hz	min ⁻¹	W	A	m ³ /h	Pa	cfm	in. wg
1	230	50	2600	42	0.19	260	0	150	0.00
2	230	50	2605	42	0.19	220	50	130	0.20
3	230	50	2595	42	0.19	175	100	105	0.40
4	230	50	2630	41	0.18	135	150	80	0.60

U = Voltage · f = Frequency · n = Speed (rpm) · P_e = Power consumption · I = Current draw · q_v = Air flow · p_{fs} = Pressure increase



Curves: Air performance 60 Hz

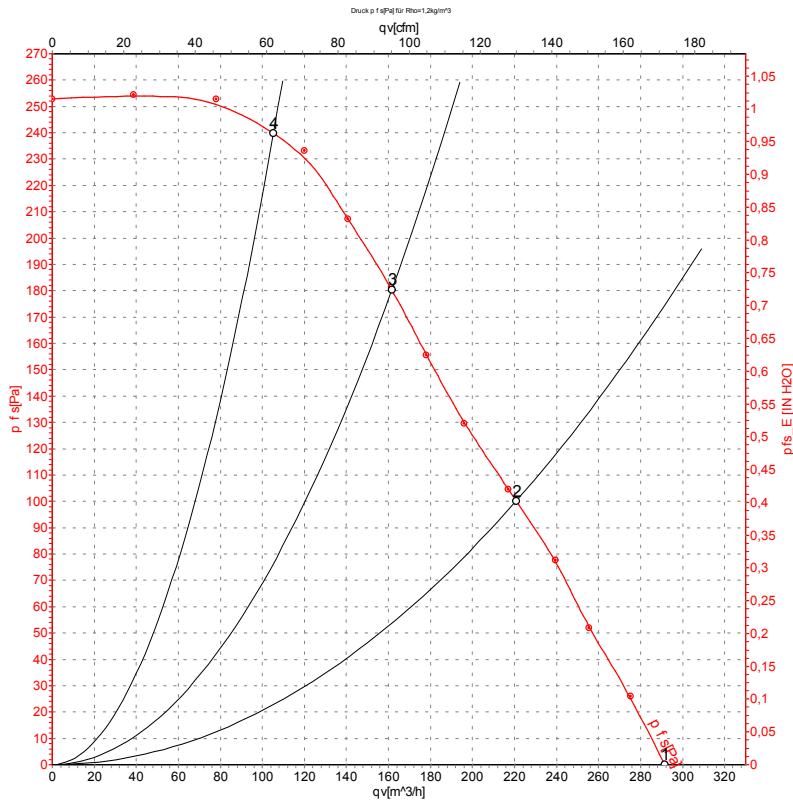

Measurement: LU-37285-1

Air performance measured according to ISO 5801 installation category A. For detailed information on the measurement setup, contact ebm-papst. Intake sound level: Sound power level according to ISO 13347 / sound pressure level measured at 1 m distance from fan axis. The values given are valid under the specified measuring conditions and may vary due to conditions of installation. For deviations from the standard configuration, the parameters have to be checked on the installed unit.

Measured values

	U	f	n	P _e	I	q _v	P _{fs}	q _v	P _{fs}
	V	Hz	min ⁻¹	W	A	m ³ /h	Pa	cfm	in. wg
1	230	60	2950	53	0.24	290	0	170	0.00
2	230	60	2915	53	0.24	220	100	130	0.40
3	230	60	2960	52	0.23	160	180	95	0.72
4	230	60	3080	49	0.22	105	240	60	0.96

U = Voltage · f = Frequency · n = Speed (rpm) · P_e = Power consumption · I = Current draw · q_v = Air flow · P_{fs} = Pressure increase

