

K3G190-RD45-24

EC centrifugal module - RadiCal

backward-curved, single-intake

with housing



ASIA PACIFIC SHENGRUI LIMITED

Phone +00852 56261528

info@apacfan.com

www.apacfan.com

Nominal data

Type	K3G190-RD45-24	
Motor	M3G055-CF	
Phase		1~
Nominal voltage	VAC	230
Nominal voltage range	VAC	200 .. 240
Frequency	Hz	50/60
Method of obtaining data		ml
Speed (rpm)	min ⁻¹	4120
Power consumption	W	169
Current draw	A	1.35
Min. ambient temperature	°C	-25
Max. ambient temperature	°C	60

ml = Max. load · me = Max. efficiency · fa = Free air · cs = Customer specification · ce = Customer equipment
Subject to change

Data according to Commission Regulation (EU) 327/2011 (prEN 17166)

		Actual	Req. 2015			
01 Overall efficiency η_{es}	%	56	43.3	09 Power consumption P_{ed}	kW	0.16
02 Measurement category		A		09 Air flow q_v	m ³ /h	640
03 Efficiency category		Static		09 Pressure increase p_{fs}	Pa	455
04 Efficiency grade N		74.7	62	10 Speed (rpm) n	min ⁻¹	4070
05 Variable speed drive		Yes		11 Specific ratio*		1.01

Data obtained at optimum efficiency level.

* Specific ratio = $1 + p_g / 100\,000\text{ Pa}$

LU-132500

The efficiency values displayed for achieving conformity with the Ecodesign Regulation EU 327/2011 has been reached with defined air duct components (e.g. inlet rings). The dimensions must be requested from ebmpapst. If other air conduction geometries are used on the installation side, the ebmpapst evaluation loses its validity/the conformity must be confirmed again. The product does not fall within the scope of Regulation (EU) 2019/1781 due to the exception specified in Article 2 (2a) (motors completely integrated into a product).



Technical description

Weight	1.8 kg
Size	190 mm
Motor size	55
Rotor surface	Thick-film passivated
Impeller material	PP plastic
Housing material	PA plastic
Number of blades	7
Direction of rotation	Clockwise, viewed toward rotor
Degree of protection	IP54
Insulation class	"B"
Moisture (F) / Environmental (H) protection class	H1
Max. permitted ambient temp. for motor (transport/storage)	+ 80 °C
Min. permitted ambient temp. for motor (transport/storage)	- 40 °C
Installation position	Any
Condensation drainage holes	None, open rotor
Mode	S1
Motor bearing	Ball bearing
Technical features	<ul style="list-style-type: none"> - Output 10 VDC, max. 10 mA - Fault output (open collector) - Power limiter - Motor current limitation - Soft start - Control input 0-10 VDC / PWM - Control interface with SELV potential safely disconnected from the mains - Overvoltage detection - Thermal overload protection for electronics/motor - Line undervoltage detection
EMC immunity to interference	According to EN 61000-6-2 (industrial environment)
EMC interference emission	According to EN 61000-6-4 (industrial environment)
Touch current according to IEC 60990 (measuring circuit Fig. 4, TN system)	<= 3.5 mA
Motor protection	Electronic motor protection
With cable	Variable
Protection class assignment	I; If a protective earth is connected by the customer This component for installation may have several local protection classes. This information relates to this component's basic design. The final protection class is based on the component's intended installation and connection.
Conformity with standards	EN 60034-1; EN 60204-1; EN 60335-1; CE
Approval	CSA C22.2 No. 77 + CAN/CSA-E60730-1; CCC; UL 1004-7 + 60730-1

EC centrifugal module - RadiCal

backward-curved, single-intake
with housing

Product drawing

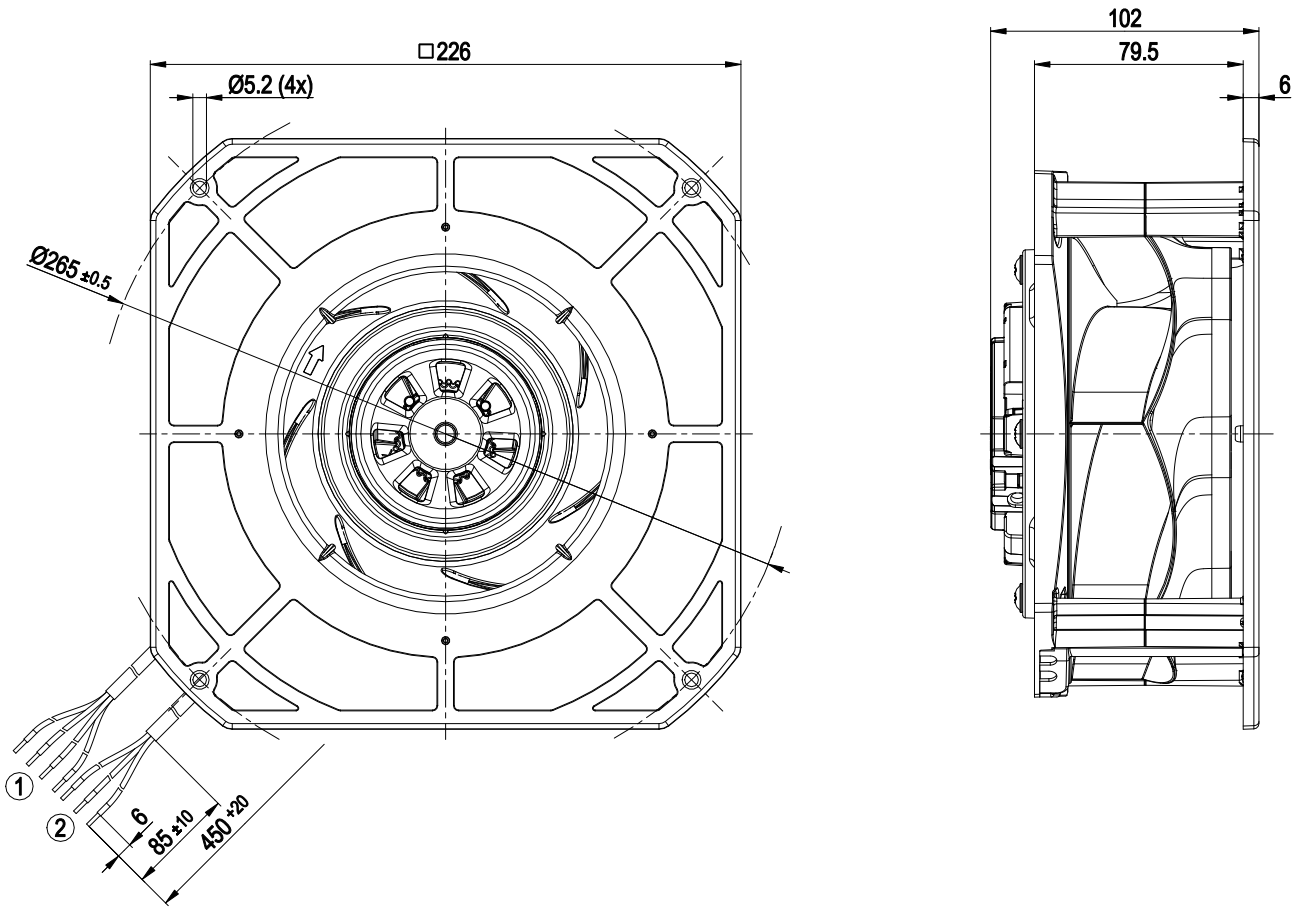

1	Cable PVC AWG22	4x splice	2	Cable PVC AWG20
	3x splice			



Mounting dimensions

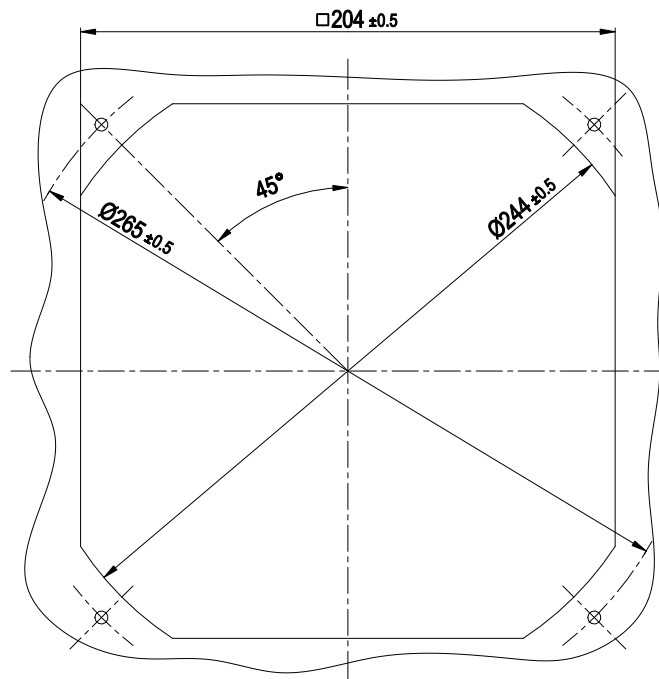

EC centrifugal module - RadiCal

backward-curved, single-intake
with housing

Connection diagram

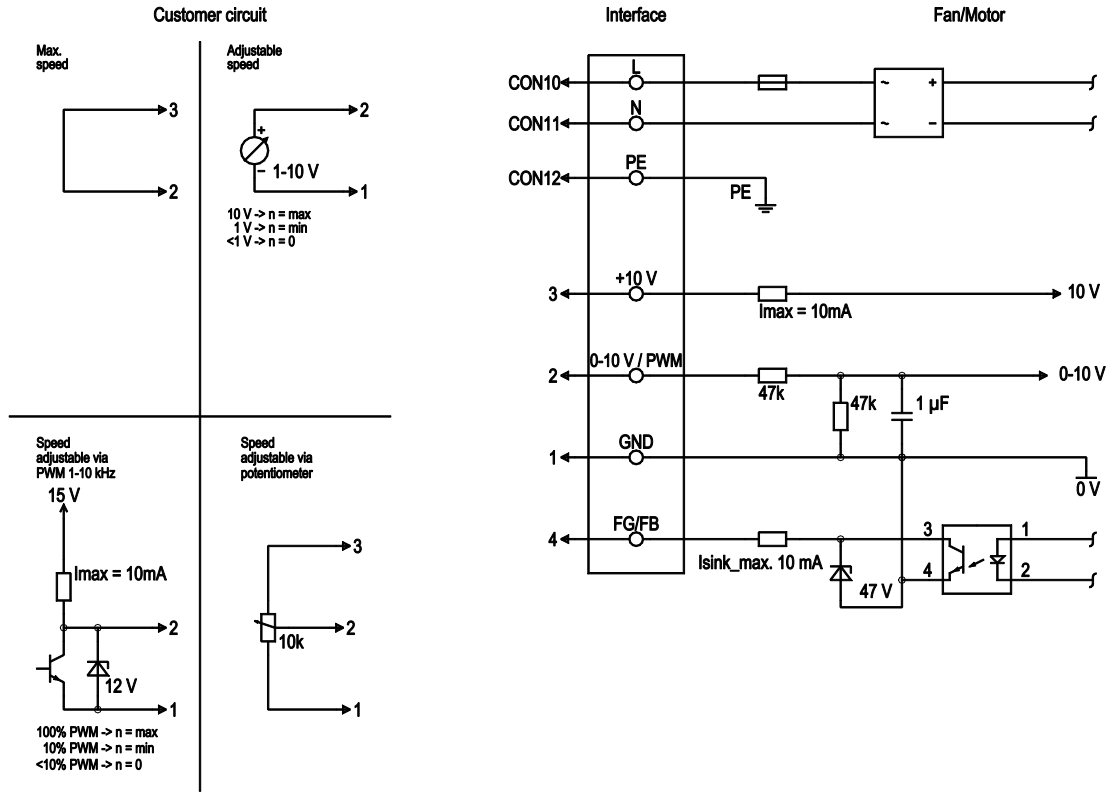

No.	Conn.	Designation	Color	Function/assignment
	CON10	L	black	Supply connection, power supply, phase, see nameplate for voltage range
	CON11	N	blue	Supply connection, power supply, neutral conductor, see nameplate for voltage range
	CON12	PE	green/yellow	Ground connection
	2	0- 10V PWM	yellow	0-10 V / PWM control input, R _i =100 kΩ, SELV
	3	+10 V	red	Fixed voltage output 10 VDC +/-3 %, I _{max} . 10 mA, short-circuit-proof, power supply for ext. devices (e.g. pot), SELV
	1	GND	blue	Reference ground for control interface, SELV
	4	FG/FB	white	Fan good / fan bad: open collector, fan good = low, electrically isolated, I _{sink} max = 10 mA, SELV



Curves: Air performance 50 Hz

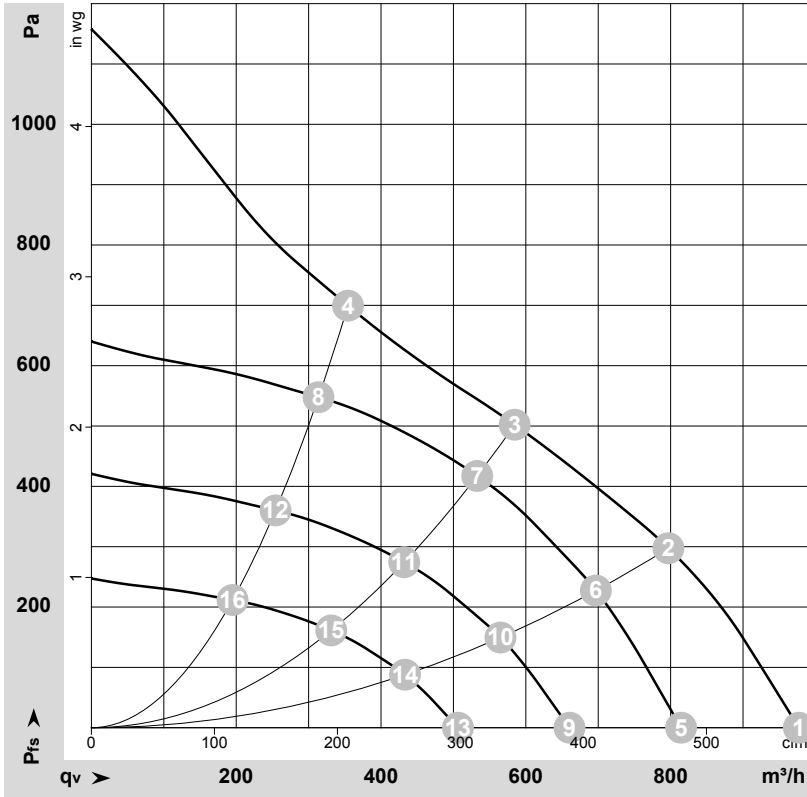

$\rho = 1.15 \text{ kg/m}^3 \pm 2 \%$

Measurement: LU-132500-1

Air performance measured according to ISO 5801 installation category A. For detailed information on the measurement setup, contact ebmpapst. Intake sound level: Sound power level according to ISO 13347 / sound pressure level measured at 1 m distance from fan axis. The values given are valid under the specified measuring conditions and may vary due to conditions of installation. For deviations from the standard configuration, the parameters have to be checked on the installed unit.

Measured values

	U	f	n	P _{ed}	I	LpA _{in}	LwA _{in}	q _v	P _{fs}	q _v	P _{fs}
	V	Hz	min ⁻¹	W	A	dB(A)	dB(A)	m ³ /h	Pa	cfm	in. wg
1	230	50	4440	161	1.35	72	81	975	0	575	0.00
2	230	50	4230	165	1.35	67	75	795	300	470	1.20
3	230	50	4120	169	1.35	63	71	585	500	345	2.01
4	230	50	4180	160	1.35	67	75	355	700	210	2.81
5	230	50	3700	93	0.80	68	77	815	0	480	0.00
6	230	50	3700	110	0.94	63	72	695	230	410	0.92
7	230	50	3700	126	1.07	60	69	535	417	315	1.67
8	230	50	3700	111	0.95	64	72	315	548	185	2.20
9	230	50	3000	50	0.43	63	71	660	0	390	0.00
10	230	50	3000	59	0.50	58	67	565	152	335	0.61
11	230	50	3000	67	0.57	55	64	430	274	255	1.10
12	230	50	3000	59	0.51	58	66	255	360	150	1.45
13	230	50	2300	22	0.19	56	65	505	0	300	0.00
14	230	50	2300	27	0.22	51	60	435	89	255	0.36
15	230	50	2300	30	0.26	48	57	330	161	195	0.65
16	230	50	2300	27	0.23	52	60	195	212	115	0.85

U = Voltage · f = Frequency · n = Speed (rpm) · P_{ed} = Power consumption · I = Current draw · LpA_{in} = Sound pressure level intake side · LwA_{in} = Sound power level intake side
q_v = Air flow · p_{fs} = Pressure increase

