

R3G630-AB06-03

EC centrifugal fan

backward-curved, single-intake



ASIA PACIFIC SHENGRUI LIMITED

Phone +00852 56261528

info@apacfan.com

www.apacfan.com

Nominal data

Type	R3G630-AB06-03	
Motor	M3G150-IF	
Phase		3~
Nominal voltage	VAC	400
Nominal voltage range	VAC	380 .. 480
Frequency	Hz	50/60
Method of obtaining data		ml
Speed (rpm)	min ⁻¹	1200
Power consumption	W	2800
Current draw	A	4.2
Min. ambient temperature	°C	-25
Max. ambient temperature	°C	50

ml = Max. load · me = Max. efficiency · fa = Free air · cs = Customer specification · ce = Customer equipment
Subject to change

Data according to Commission Regulation (EU) 327/2011

		Actual	Req. 2015
01 Overall efficiency η_{es}	%	57.9	56.2
02 Measurement category		A	
03 Efficiency category		Static	
04 Efficiency grade N		63.7	62
05 Variable speed drive		Yes	

Data obtained at optimum efficiency level.

The ErP data is determined using a motor-impeller combination in a standardized measurement setup.

09 Power consumption P_{ed}	kW	2.81
09 Air flow q_v	m ³ /h	10005
09 Pressure increase p_{fs}	Pa	555
10 Speed (rpm) n	min ⁻¹	1210
11 Specific ratio*		1.01

* Specific ratio = $1 + p_{fs} / 100\,000\text{ Pa}$

LU-109182



Technical description

Weight	29 kg
Size	630 mm
Motor size	150
Rotor surface	Painted black
Electronics housing material	Die-cast aluminum
Impeller material	Sheet aluminum
Number of blades	6
Direction of rotation	Clockwise, viewed toward rotor
Degree of protection	IP55
Insulation class	"F"
Moisture (F) / Environmental (H) protection class	F4-1
Max. permitted ambient temp. for motor (transport/storage)	+80 °C
Min. permitted ambient temp. for motor (transport/storage)	-40 °C
Installation position	Shaft horizontal or rotor on bottom; rotor on top on request
Condensation drainage holes	On rotor side
Mode	Continuous operation (S1)
Motor mounting	Ball bearing
Technical features	<ul style="list-style-type: none"> - Output 10 VDC, max. 10 mA - Output 20 VDC, max. 50 mA - Output for slave 0-10 V - Input for sensor 0-10 V or 4-20 mA - Alarm relay - Integrated PID controller - Motor current limitation - PFC, passive - RS-485 ebmBUS - Soft start - Control input 0-10 VDC / PWM - Control interface with SELV potential safely disconnected from supply - Thermal overload protection for electronics/motor - Line undervoltage / phase failure detection
EMC immunity to interference	According to EN 61000-6-2 (industrial environment)
EMC interference emission	According to EN 61000-6-3 (household environment)
Touch current according to IEC 60990 (measuring circuit Fig. 4, TN system)	<= 3.5 mA
Electrical hookup	Terminal box
Motor protection	Reverse polarity and locked-rotor protection
Protection class	I (with customer connection of protective earth)
Conformity with standards	EN 61800-5-1; CE
Approval	VDE; CSA C22.2 No. 77; EAC

EC centrifugal fan

backward-curved, single-intake

Product drawing

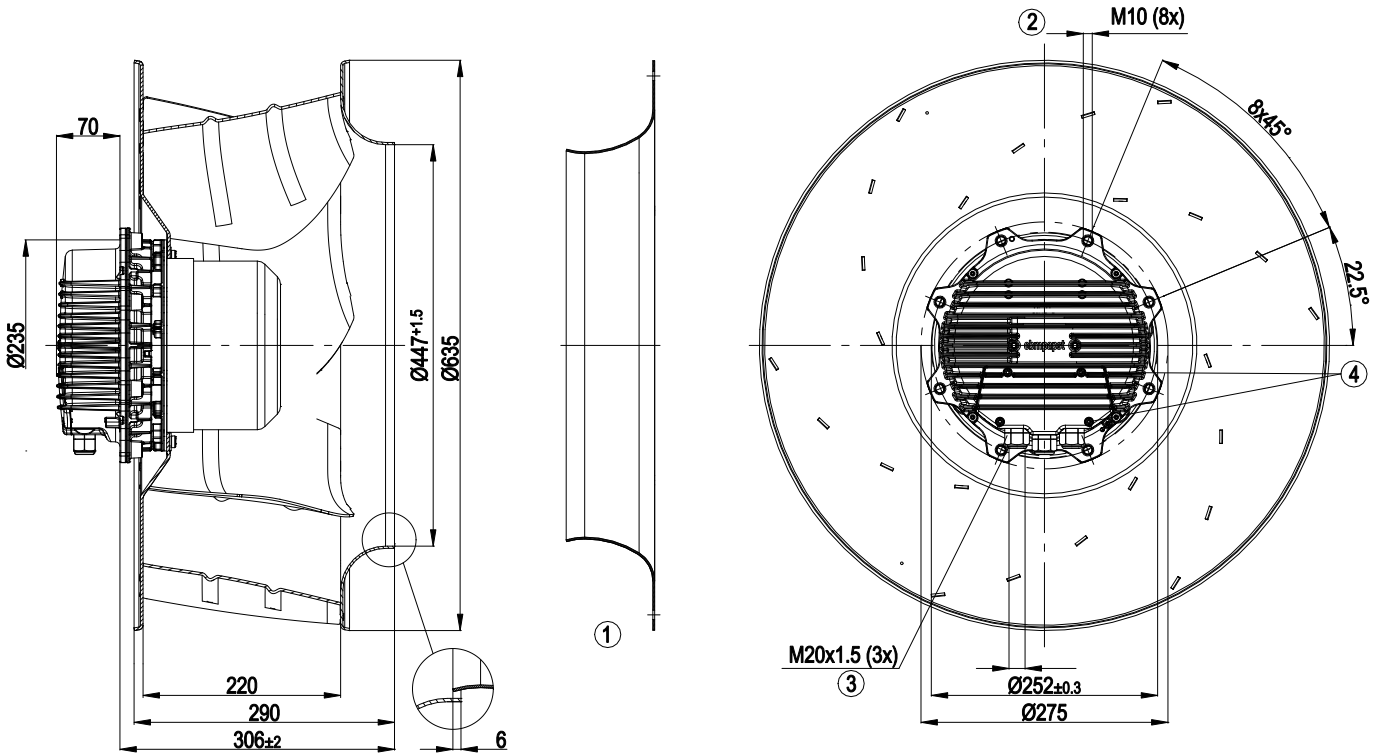

1	Accessory part: inlet ring 63070-2-4013 not included in scope of delivery
2	Max. clearance for screw 25 mm
3	Cable diameter min. 4 mm, max. 10 mm, tightening torque 4 ± 0.6 Nm
4	Tightening torque 3.5 ± 0.5 Nm



Accessory part

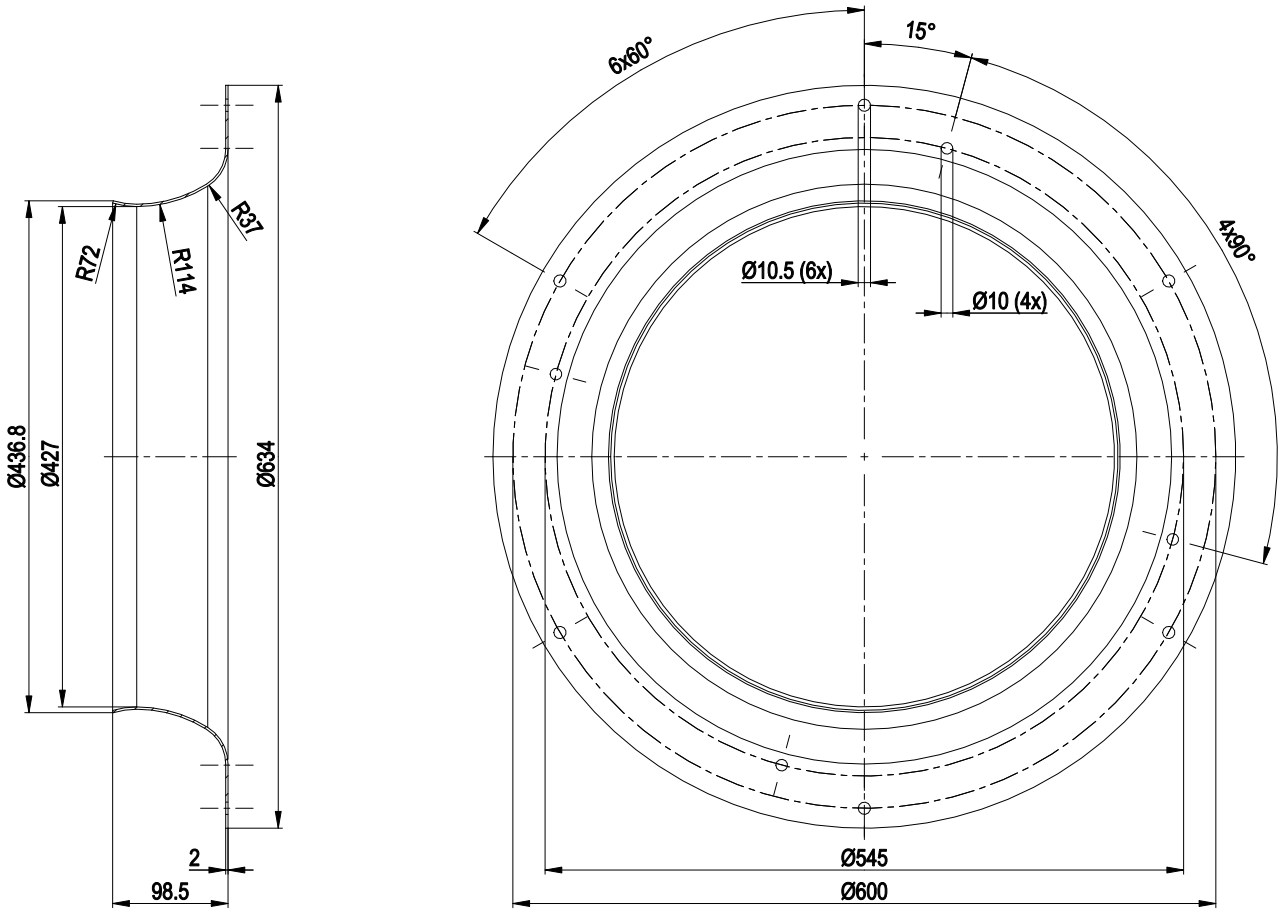

Inlet ring 63070-2-4013 not included in scope of delivery

Connection diagram

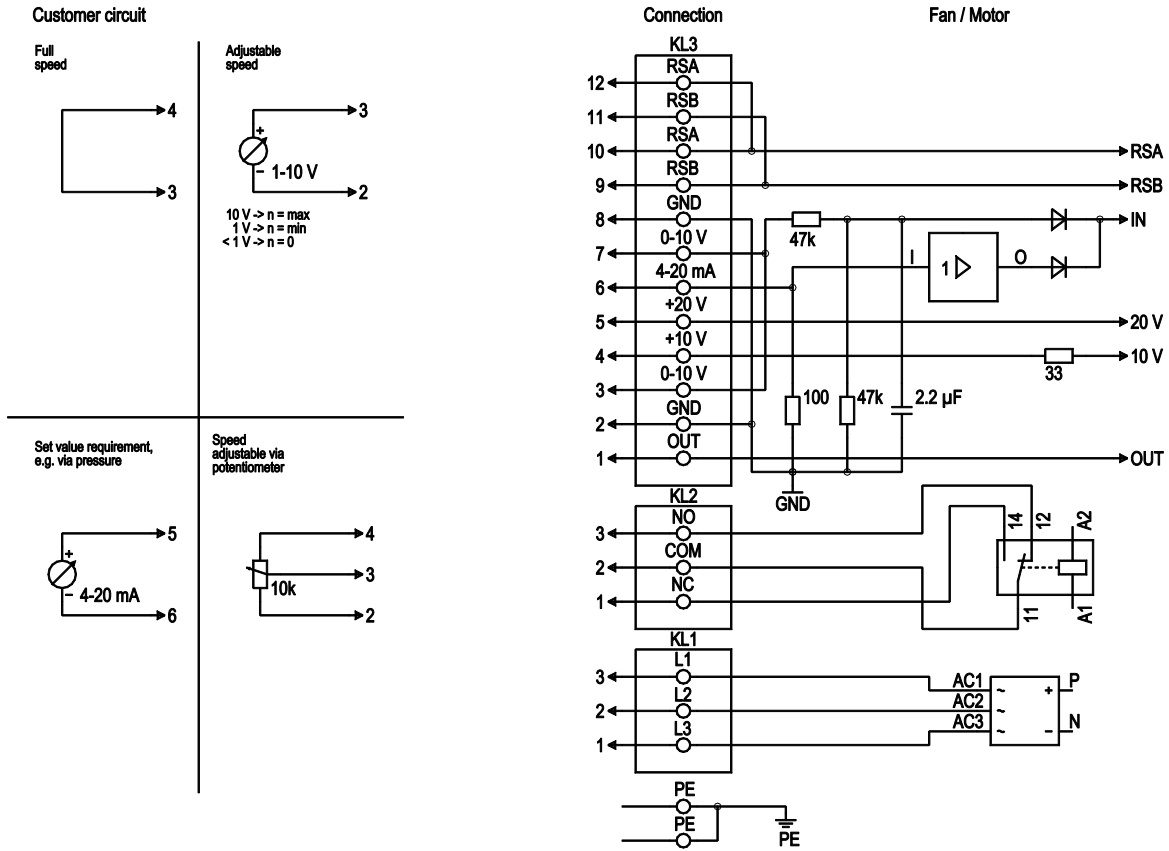

No.	Conn.	Designation	Function/assignment
PE		PE	Protective earth terminal
KL1	1, 2, 3	L1, L2, L3	Power supply 50/60 Hz
KL2	1	NC	Floating status contact, break for failure
KL2	2	COM	floating status contact, changeover contact, common connection (2 A, max. 250 VAC, min. 10 mA, AC1)
KL2	3	NO	Floating status contact, make for failure
KL3	1	OUT	Analog output, 0-10 VDC, max. 3 mA, SELV, output of current motor modulation level: 1 V corresponds to 10 % modulation level. 10 V corresponds to 100 % modulation level.
KL3	2, 8	GND	Reference ground for control interface, SELV
KL3	3, 7	0-10 V	Use control / current sensor value input 0-10 VDC, impedance 100 kΩ only as alternative to 4-20 mA input, SELV
KL3	4	+10 V	Voltage output 10 VDC (±3 %), max. 10 mA, power supply for external devices (e.g. potentiometer), SELV
KL3	5	+20 V	Voltage output 20 VDC (+25% / -10%), max. 50 mA, power supply for external devices (e.g. sensors); SELV
KL3	6	4-20 mA	Use control / current sensor value input 4-20 mA, impedance 100 Ω only as alternative to 0-10 V input, SELV
KL3	9, 11	RSB	RS485 interface for ebmBUS, RSB, SELV
KL3	10, 12	RSA	RS485 interface for ebmBUS, RSA, SELV

Curves: Air performance 50 Hz

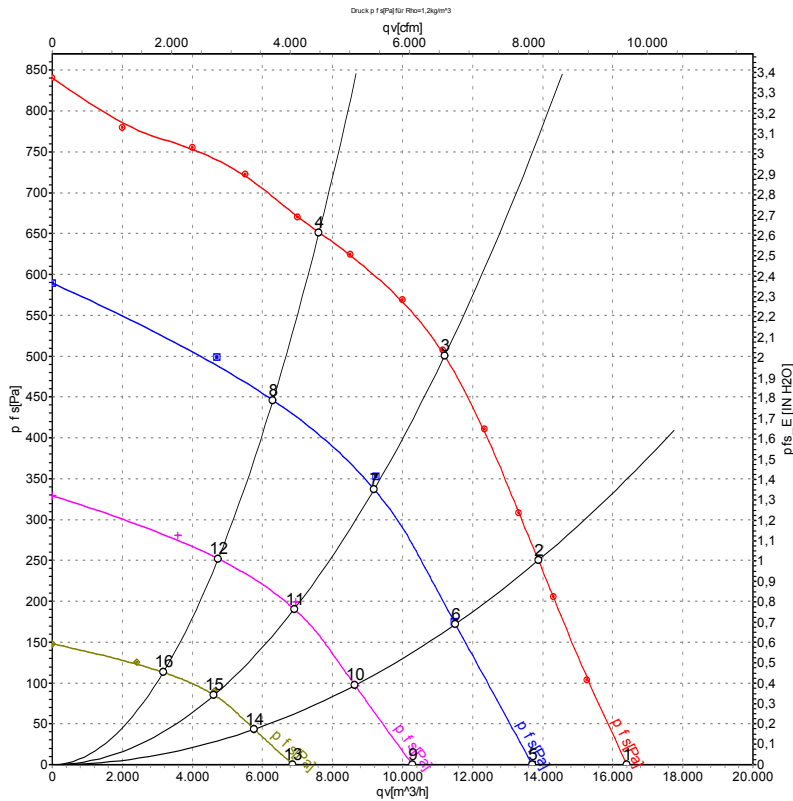

Measurement: LU-109182-1
 Measurement: LU-116038-1
 Measurement: LU-114211-1
 Measurement: LU-114210-1

Air performance measured according to ISO 5801 installation category A. For detailed information on the measurement setup, contact ebmpapst. Intake sound level: Sound power level according to ISO 13347 / sound pressure level measured at 1 m distance from fan axis. The values given are valid under the specified measuring conditions and may vary due to conditions of installation. For deviations from the standard configuration, the parameters have to be checked on the installed unit.

Measured values

	Wired	U	f	n	P _{ed}	I	LpA _{in}	LwA _{in}	LwA _{out}	q _v	p _{fs}	q _v	p _{fs}
		V	Hz	min ⁻¹	W	A	dB(A)	dB(A)	dB(A)	m ³ /h	Pa	cfm	in. wg
1	Y	400	50	1200	2020	3.07	78	85	91	16410	0	9660	0.00
2	Y	400	50	1200	2458	3.72	74	82	88	13880	250	8170	1.00
3	Y	400	50	1200	2800	4.20	72	79	86	11200	500	6590	2.01
4	Y	400	50	1200	2629	3.98	73	81	87	7615	650	4480	2.61
5	Y	400	50	1000	1103	1.70	72	79	85	13700	0	8065	0.00
6	Y	400	50	1000	1315	2.01	69	76	82	11510	171	6775	0.69
7	Y	400	50	1000	1520	2.32	67	74	81	9190	354	5410	1.42
8	Y	400	50	1000	1338	2.05	68	75	82	6300	447	3710	1.79
9	Y	400	50	750	474	0.82	64	71	77	10280	0	6050	0.00
10	Y	400	50	750	554	0.92	61	68	74	8645	96	5085	0.39
11	Y	400	50	750	654	1.05	59	67	73	6905	200	4065	0.80
12	Y	400	50	750	572	0.94	60	67	74	4735	253	2790	1.02
13	Y	400	50	500	161	0.35	53	60	66	6870	0	4040	0.00
14	Y	400	50	500	179	0.38	50	57	63	5765	43	3395	0.17
15	Y	400	50	500	208	0.43	49	57	63	4620	90	2720	0.36
16	Y	400	50	500	188	0.40	49	56	63	3170	113	1865	0.45

Wired = Wiring · U = Power supply · f = Frequency · n = Speed (rpm) · P_{ed} = Power consumption · I = Current draw · LpA_{in} = Sound pressure level intake side · LwA_{in} = Sound power level intake side
 LwA_{out} = Sound power level outlet side · q_v = Air flow · p_{fs} = Pressure increase

