



## ASIA PACIFIC SHENGRUI LIMITED

Phone +00852 56261528

info@apacfan.com

www.apacfan.com



## Nominal data

Type	R3G190-RD45-03	
Motor	M3G055-CF	
Phase		1~
Nominal voltage	VAC	230
Nominal voltage range	VAC	200 .. 240
Frequency	Hz	50/60
Type of data definition		ml
Speed	min <sup>-1</sup>	4120
Power input	W	169
Current draw	A	1.35
Min. ambient temperature	°C	-25
Max. ambient temperature	°C	60

ml = Max. load · me = Max. efficiency · fa = Running at free air · cs = Customer specs · cu = Customer unit  
Subject to alterations

## Data according to ErP directive

Installation category	A
Efficiency category	Static
Variable speed drive	Yes
Specific ratio*	1.01

\* Specific ratio =  $1 + p_{fs} / 100\,000\text{ Pa}$

		Actual	Request 2013	Request 2015
Overall efficiency $\eta_{es}$	%	56	39.1	43.1
Efficiency grade N		74.9	58	62
Power input $P_{ed}$	kW	0.16		
Air flow $q_v$	m <sup>3</sup> /h	565		
Pressure increase $p_{fs}$	Pa	524		
Speed n	min <sup>-1</sup>	4055		

Data definition with optimum efficiency. LU-132500  
The ErP data is determined using a motor-impeller combination in a standardised measurement configuration.



## Technical features

<b>Mass</b>	1.38 kg
<b>Size</b>	190 mm
<b>Surface of rotor</b>	Thick layer passivated
<b>Material of electronics housing</b>	Die-cast aluminium
<b>Material of impeller</b>	Plastic PA6, fibreglass-reinforced
<b>Number of blades</b>	7
<b>Direction of rotation</b>	Clockwise, seen on rotor
<b>Type of protection</b>	IP 54
<b>Insulation class</b>	"B"
<b>Max. permissible ambient motor temp. (transp./ storage)</b>	+ 80 °C
<b>Min. permissible ambient motor temp. (transp./storage)</b>	- 40 °C
<b>Mounting position</b>	Shaft horizontal or rotor on bottom; rotor on top on request
<b>Condensate discharge holes</b>	None, open rotor
<b>Operation mode</b>	S1
<b>Motor bearing</b>	Ball bearing
<b>Technical features</b>	<ul style="list-style-type: none"> <li>- Output 10 VDC, max. 1.1 mA</li> <li>- Tach output</li> <li>- Motor current limit</li> <li>- Soft start</li> <li>- Control input 0-10 VDC / PWM</li> <li>- Over-temperature protected electronics / motor</li> <li>- Line undervoltage detection</li> </ul>
<b>Touch current acc. IEC 60990 (measuring network Fig. 4, TN system)</b>	<= 3.5 mA
<b>Motor protection</b>	Locked-rotor protection
<b>Cable exit</b>	Variable
<b>Protection class</b>	I (if protective earth is connected by customer)
<b>Product conforming to standard</b>	EN 60335-1; CE
<b>Approval</b>	CCC; CSA C22.2 Nr.77; EAC; UL 2111

Product drawing

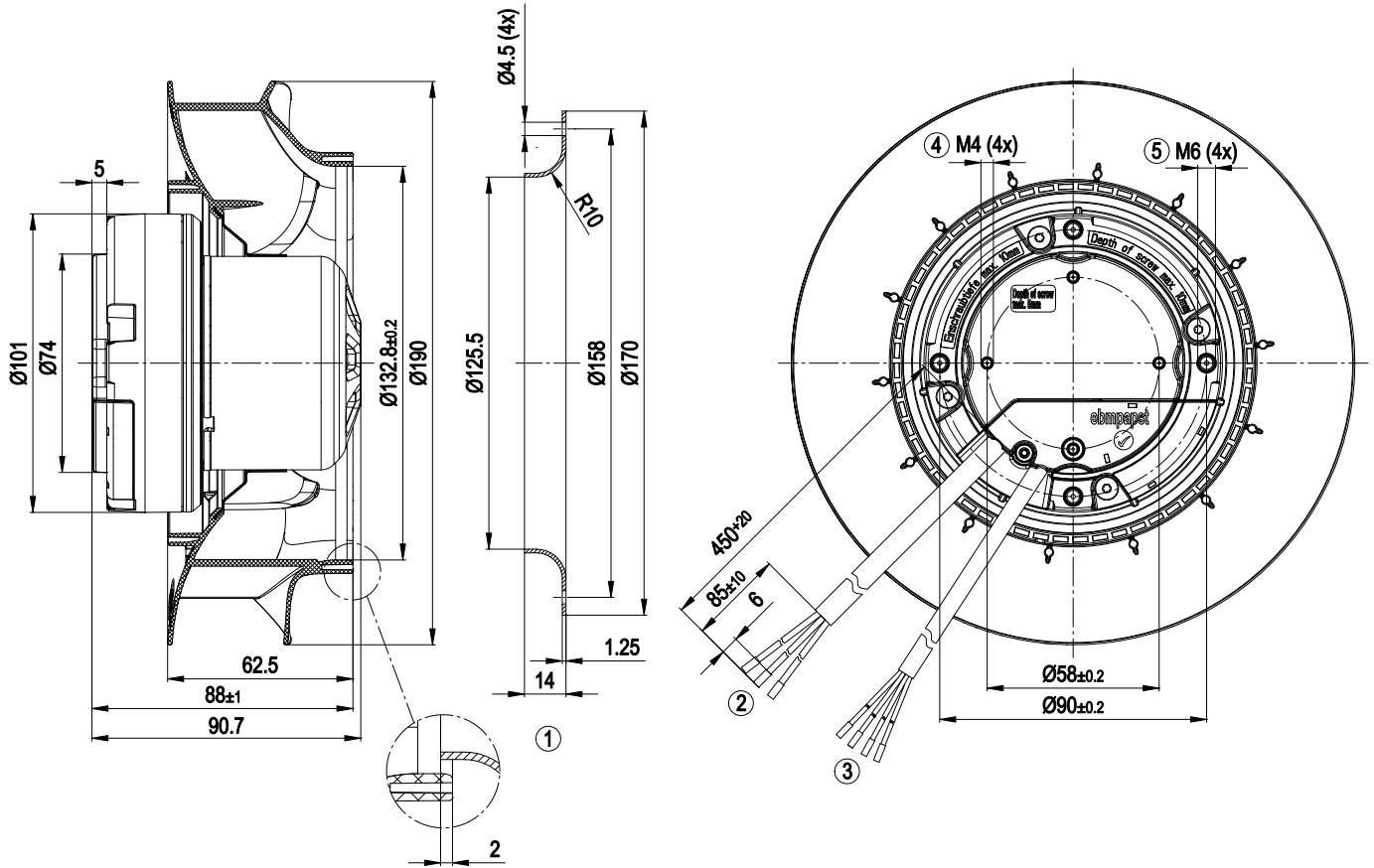

1	Accessory part: Inlet nozzle 09576-2-4013, not included in the standard scope of delivery
2	Connection line PVC 3G AWG20; 3 x brass lead tips crimped
3	Control line PVC 4X AWG22; 4 x brass lead tips crimped
4	Depth of screw max. 5 mm
5	Depth of screw max. 10 mm

## Connection screen

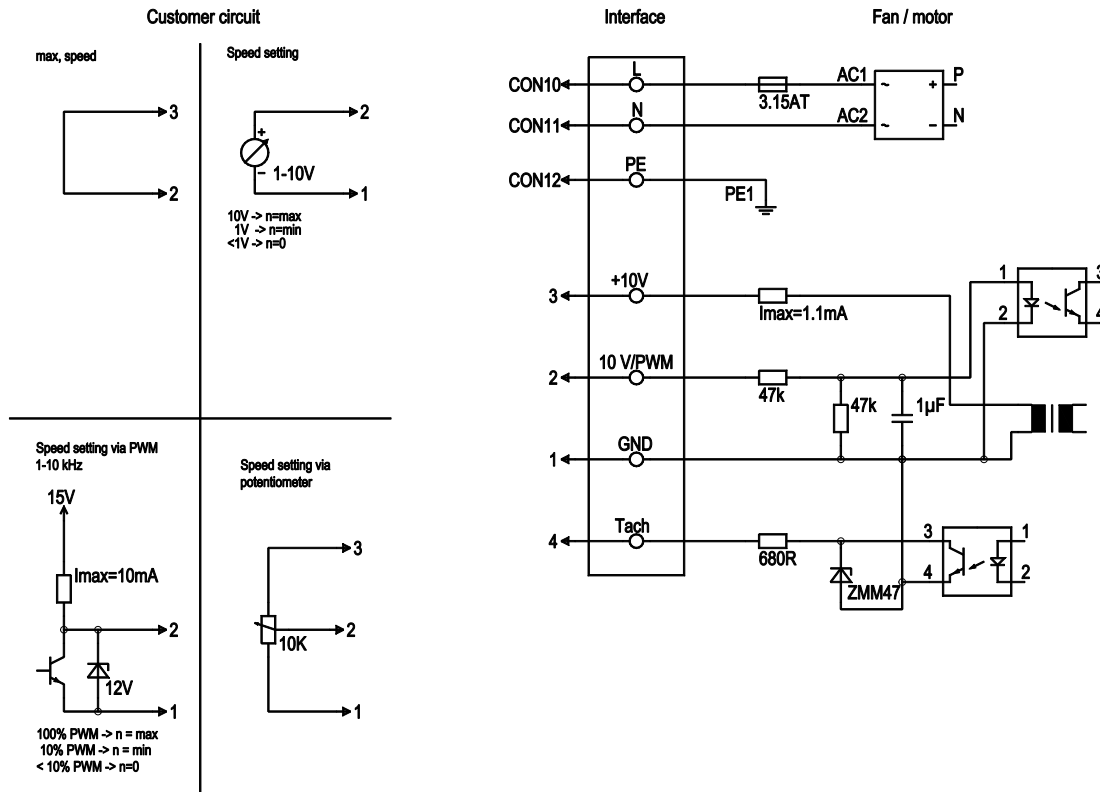

No.	Conn.	Designation	Colour	Function / assignment
	CON10	L	black	Power supply 230 VAC, 50-60 Hz, for voltage range refer to rating plate
	CON11	N	blue	Neutral conductor
	CON12	PE	green/yellow	Protective earth
	1	GND	blue	GND - Connection for control interface
	2	0- 10V PWM	yellow	Control input 0 - 10 V or PWM, electrically isolated
	3	10V/ max 1.1mA	red	Voltage output 10V/ 1.1mA, electrically isolated, not short-circuit-proof.
	4	Tach	white	Tach output: open collector, 1 pulse per revolution, electrically isolated

## Charts: Air flow 50 Hz

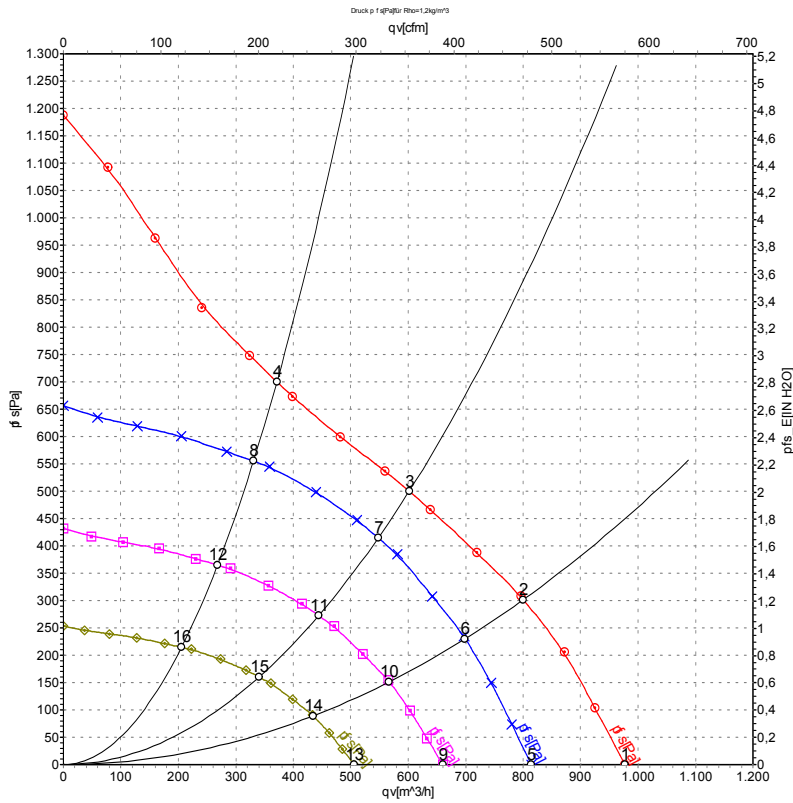

Air performance measured as per ISO 5801 Installation category A. For detailed information on the measuring set-up, please contact ebm-papst. Suction-side noise levels: L<sub>wA</sub> measured as per ISO 13347 / L<sub>pA</sub> measured with 1m distance to fan axis. The values given are valid under the measuring conditions mentioned above and may vary according to the actual installation situation. With any deviation from the standard set-up, the specific values have to be checked and reviewed with the unit installed.

## Measured values

	U	f	n	P <sub>ed</sub>	I	L <sub>pA<sub>in</sub></sub>	L <sub>wA<sub>in</sub></sub>	qv	p <sub>fs</sub>
	V	Hz	min <sup>-1</sup>	W	A	dB(A)	dB(A)	m <sup>3</sup> /h	Pa
1	230	50	4440	161	1.35	72	81	975	0
2	230	50	4235	165	1.35	67	75	800	300
3	230	50	4120	169	1.35	63	72	600	500
4	230	50	4150	160	1.35	66	74	370	700
5	230	50	3700	93	0.81	69	77	815	0
6	230	50	3700	110	0.93	64	72	700	233
7	230	50	3700	125	1.06	61	70	550	415
8	230	50	3700	114	0.97	64	72	330	556
9	230	50	3000	50	0.43	64	73	660	0
10	230	50	3000	59	0.50	59	68	565	153
11	230	50	3000	67	0.57	56	65	445	273
12	230	50	3000	61	0.52	59	67	270	365
13	230	50	2300	22	0.19	58	67	505	0
14	230	50	2300	26	0.22	53	62	435	90
15	230	50	2300	30	0.26	51	59	340	160
16	230	50	2300	27	0.23	54	61	205	215

U = Supply voltage · f = Frequency · n = Speed · P<sub>ed</sub> = Power input · I = Current draw · L<sub>pA<sub>in</sub></sub> = Sound pressure level inlet side · L<sub>wA<sub>in</sub></sub> = Sound power level inlet side · qv = Air flow  
 p<sub>fs</sub> = Pressure increase

