

D2E146-AZ03-F9

AC centrifugal fan

forward-curved, dual-intake

with housing (flange)

ASIA PACIFIC SHENGRUI LIMITED

Phone +00852 56261528

info@apacfan.com

www.apacfan.com

Nominal data

Type	D2E146-AZ03-F9			
Motor	M2E074-EI			
Phase		1~	1~	1~
Nominal voltage	VAC	230	230	230
Frequency	Hz	50	60	60
Method of obtaining data		ml	ml	ml
Valid for approval/standard		-	-	UL 2111
Speed (rpm)	min ⁻¹	2300	2500	2500
Power consumption	W	330	365	380
Current draw	A	1.44	1.59	1.65
Capacitor	μF	7	7	7
Capacitor voltage	VDB	400	400	400
Capacitor standard		S2 (CE)	S2 (CE)	UL
Min. back pressure	Pa	235	350	350
Min. back pressure	in. wg	0.94	1.41	1.41
Min. ambient temperature	°C	-25	-25	-25
Max. ambient temperature	°C	65	50	50

ml = Max. load · me = Max. efficiency · fa = Free air · cs = Customer specification · ce = Customer equipment
Subject to change



AC centrifugal fan

forward-curved, dual-intake

with housing (flange)

Technical description

Weight	5.43 kg
Size	146 mm
Motor size	74
Rotor surface	Unpainted
Impeller material	Sheet steel, galvanized
Housing material	Sheet steel, galvanized
Motor suspension	Motor vibration-damped on one side
Direction of rotation	Counterclockwise, viewed toward rotor
Degree of protection	IP44
Insulation class	"F"
Moisture (F) / Environmental (H) protection class	H0 - dry environment
Max. permitted ambient temp. for motor (transport/storage)	+80 °C
Min. permitted ambient temp. for motor (transport/storage)	-40 °C
Installation position	Any
Condensation drainage holes	None
Mode	S1
Motor bearing	Ball bearing
Touch current according to IEC 60990 (measuring circuit Fig. 4, TN system)	< 0.75 mA
Motor protection	Thermal overload protector (TOP) with basic insulation
Protection class	I (with customer connection of protective earth)
Motor capacitor according to EN 60252-1 in safety protection class	S2
Conformity with standards	EN 60335-1
Comment on CE	Commissioning not permitted in the European Economic Area
Approval	CCC; EAC; UL 1004-3; CSA C22.2 No. 77



AC centrifugal fan

forward-curved, dual-intake
with housing (flange)

Product drawing

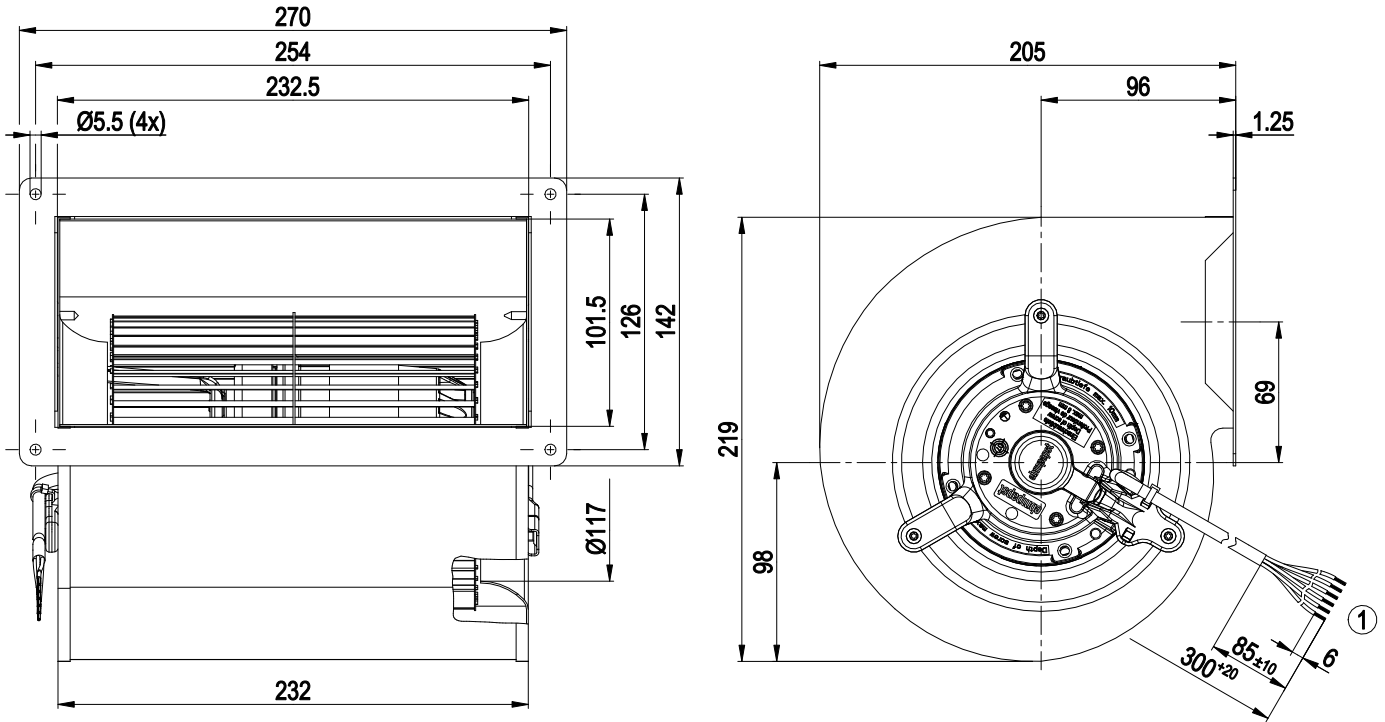

1 Cable silicone 6x 0.5 mm², 6x crimped splices

Connection diagram

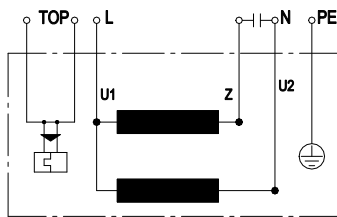

U1	blue	Z	brown	U2	black
PE	green/yellow	TOP	2x gray		



AC centrifugal fan

forward-curved, dual-intake
with housing (flange)

Curves: Air performance 50 Hz

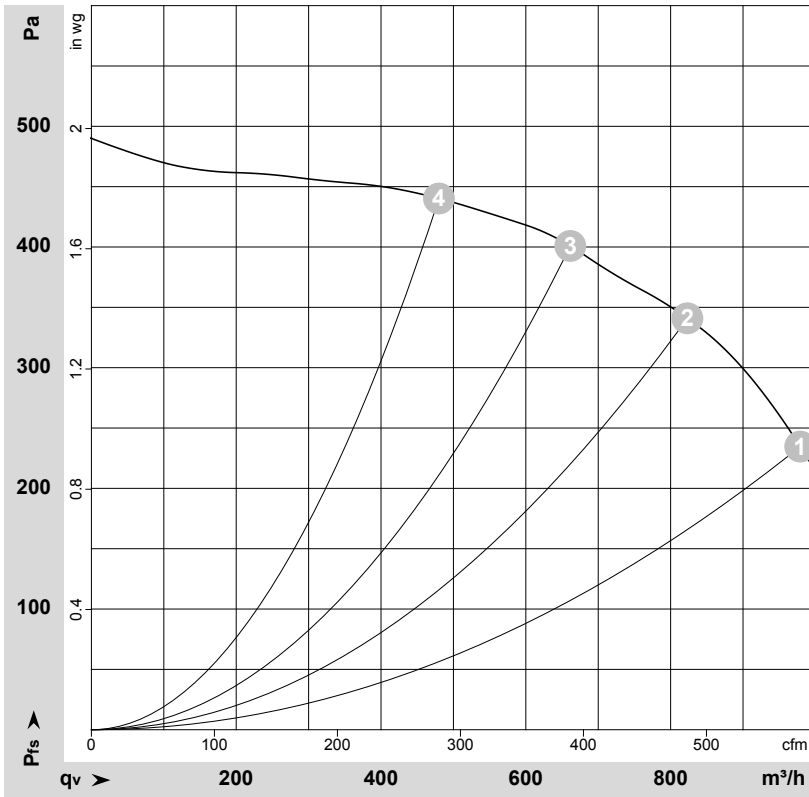

$\rho = 1.15 \text{ kg/m}^3 \pm 2 \%$

Measurement: LU-166694-1

Air performance measured according to ISO 5801 installation category A. For detailed information on the measurement setup, contact ebmpapst. Intake sound level: Sound power level according to ISO 13347 / sound pressure level measured at 1 m distance from fan axis. The values given are valid under the specified measuring conditions and may vary due to conditions of installation. For deviations from the standard configuration, the parameters have to be checked on the installed unit.

Measured values

	U	f	n	P _e	I	LpA _{in}	LwA _{in}	q _v	p _{fs}	q _v	p _{fs}
	V	Hz	min ⁻¹	W	A	dB(A)	dB(A)	m ³ /h	Pa	cfm	in. wg
1	230	50	2300	330	1.44	64	75	980	235	575	0.94
2	230	50	2500	272	1.19	64	75	825	340	485	1.36
3	230	50	2625	234	1.03	64	75	660	400	390	1.61
4	230	50	2720	198	0.88	65	75	480	440	285	1.77

U = Voltage · f = Frequency · n = Speed (rpm) · P_e = Power consumption · I = Current draw · LpA_{in} = Sound pressure level intake side · LwA_{in} = Sound power level intake side
q_v = Air flow · p_{fs} = Pressure increase



AC centrifugal fan

forward-curved, dual-intake
with housing (flange)

Curves: Air performance 60 Hz

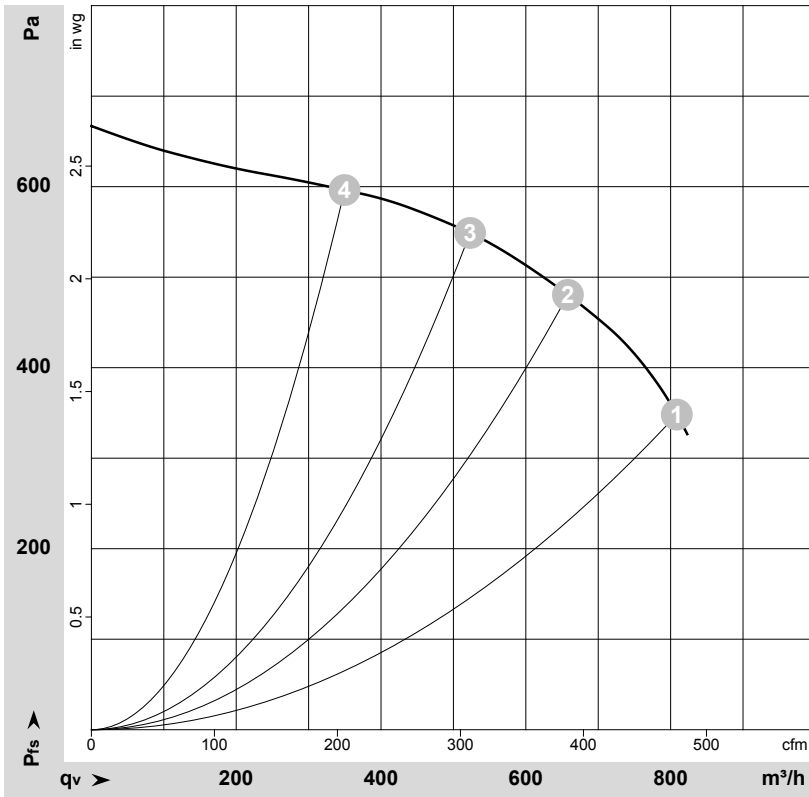

$\rho = 1.15 \text{ kg/m}^3 \pm 2 \%$

Measurement: LU-166734-1

Air performance measured according to ISO 5801 installation category A. For detailed information on the measurement setup, contact ebm-papst. Intake sound level: Sound power level according to ISO 13347 / sound pressure level measured at 1 m distance from fan axis. The values given are valid under the specified measuring conditions and may vary due to conditions of installation. For deviations from the standard configuration, the parameters have to be checked on the installed unit.

Measured values

	U	f	n	P _e	I	LpA _{in}	LwA _{in}	q _v	P _{fs}	q _v	P _{fs}
	V	Hz	min ⁻¹	W	A	dB(A)	dB(A)	m ³ /h	Pa	cfm	in. wg
1	230	60	2500	365	1.59	64	74	810	350	475	1.41
2	230	60	2850	328	1.44	66	77	660	480	385	1.93
3	230	60	3035	295	1.32	68	78	525	550	310	2.21
4	230	60	3185	259	1.21	69	80	350	600	205	2.41

U = Voltage · f = Frequency · n = Speed (rpm) · P_e = Power consumption · I = Current draw · LpA_{in} = Sound pressure level intake side · LwA_{in} = Sound power level intake side
q_v = Air flow · P_{fs} = Pressure increase

