

EC axial fan - HyBlade

sickle-shaped blades (S series)

with guard grille for full nozzle

ASIA PACIFIC SHENGRUI LIMITED

Phone +00852 56261528

info@apacfan.com

www.apacfan.com

Nominal data

Type	S3G910-CU27-06	
Motor	M3G150-IF	
Phase		3~
Nominal voltage	VAC	400
Nominal voltage range	VAC	380 .. 480
Frequency	Hz	50/60
Method of obtaining data		ml
Status		prelim.
Speed (rpm)	min ⁻¹	920-970
Power consumption	W	2300
Current draw	A	3.5
Max. back pressure	Pa	190
Max. back pressure	in. wg	0.76
Min. ambient temperature	°C	-40
Max. ambient temperature	°C	70

ml = Max. load · me = Max. efficiency · fa = Free air · cs = Customer specification · ce = Customer equipment
Subject to change

Data according to Commission Regulation (EU) 327/2011 (prEN 17166)

		Actual	Req. 2015			
01 Overall efficiency η_{es}	%	47.7	36	09 Power consumption P_{ed}	kW	2.3
02 Measurement category		A		09 Air flow q_v	m ³ /h	21120
03 Efficiency category		Static		09 Pressure increase p_{fs}	Pa	185
04 Efficiency grade N		51.7	40	10 Speed (rpm) n	min ⁻¹	920
05 Variable speed drive		Yes		11 Specific ratio*		1.00

Data obtained at optimum efficiency level.

* Specific ratio = $1 + p_g / 100\,000\text{ Pa}$

LU-207295

The efficiency values displayed for achieving conformity with the Ecodesign Regulation EU 327/2011 has been reached with defined air duct components (e.g. inlet rings).
The dimensions must be requested from ebm-papst. If other air conduction geometries are used on the installation side, the ebm-papst evaluation loses its validity/the conformity must be confirmed again.
The product does not fall within the scope of Regulation (EU) 2019/1781 due to the exception specified in Article 2 (2a) (motors completely integrated into a product).



EC axial fan - HyBlade

sickle-shaped blades (S series)

with guard grille for full nozzle

Technical description

Size	910 mm
Motor size	150
Rotor surface	Painted black
Electronics housing material	Die-cast aluminum, painted gray
Blade material	Sheet aluminum insert, sprayed with PP plastic
Guard grille material	Steel, coated with black plastic (RAL 9005)
Number of blades	5
Blade pitch	0°
Airflow direction	V
Direction of rotation	Clockwise, viewed toward rotor
Degree of protection	IP55
Insulation class	"F"
Moisture (F) / Environmental (H) protection class	H2
Ambient temperature note	Occasional start-up at temperatures between -40°C and -25°C is permitted. For continuous operation at ambient temperatures below -25°C (such as refrigeration applications), use must be made of a fan design with special low-temperature bearings.
Max. permitted ambient temp. for motor (transport/storage)	+80 °C
Min. permitted ambient temp. for motor (transport/storage)	-40 °C
Installation position	Shaft horizontal or rotor on bottom; rotor on top on request
Condensation drainage holes	On rotor side
Mode	S1
Motor bearing	Ball bearing
Technical features	<ul style="list-style-type: none"> - Operation and alarm display with LED - External 15-50 VDC input (parameterization) - Alarm relay - Integrated PI controller - Configurable inputs/outputs (I/O) - MODBUS V6.3 - Motor current limitation - RS-485 MODBUS-RTU - Soft start - Voltage output 3.3-24 VDC, Pmax = 800 mW - Control interface with SELV potential safely disconnected from the mains - Thermal overload protection for electronics/motor - Line undervoltage / phase failure detection
EMC immunity to interference	According to EN 61000-6-2 (industrial environment)
EMC interference emission	According to EN 61000-6-3 (household environment), except EN 61000-3-2 for professionally used equipment with a total rated power greater than 1 kW
Touch current according to IEC 60990 (measuring circuit Fig. 4, TN system)	<= 3.5 mA
Electrical hookup	Terminal box
Motor protection	Reverse polarity and locked-rotor protection
Protection class	I (with customer connection of protective earth)
Conformity with standards	EN 61800-5-1; UKCA; CE
Approval	EAC; UL 1004-7 + 60730-1; CSA C22.2 No. 77 + CAN/CSA-E60730-1

EC axial fan - HyBlade

sickle-shaped blades (S series)

with guard grille for full nozzle

Product drawing

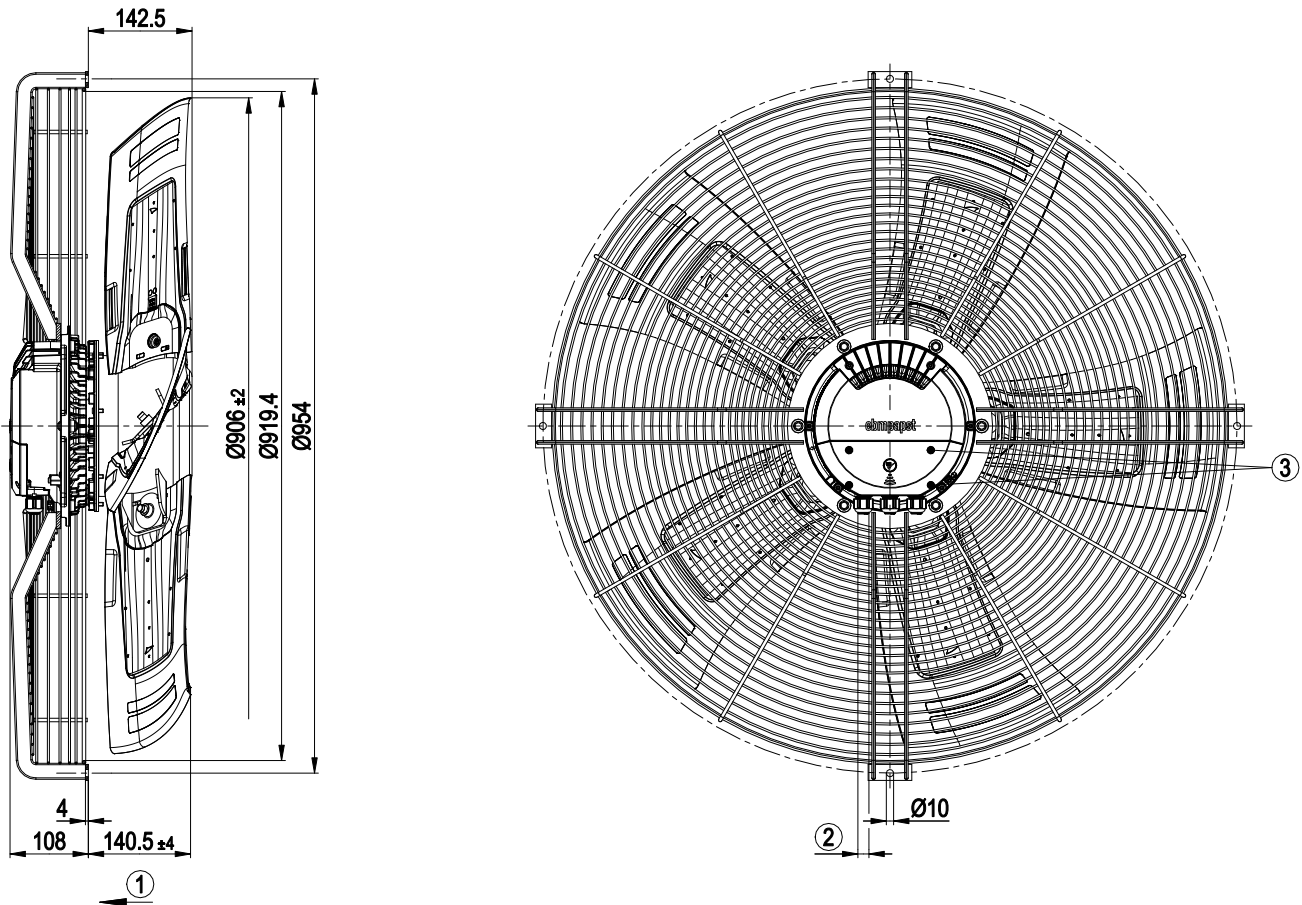

1	Airflow direction "V"
2	Cable diameter min. 4 mm, max. 10 mm, tightening torque 4 ± 0.6 Nm (The tightening torque is designed for PVC cables. If the cable materials are different, the tightening torque may have to be adjusted)
3	Tightening torque 1.5 ± 0.2 Nm

EC axial fan - HyBlade

sickle-shaped blades (S series)

with guard grille for full nozzle

Connection diagram

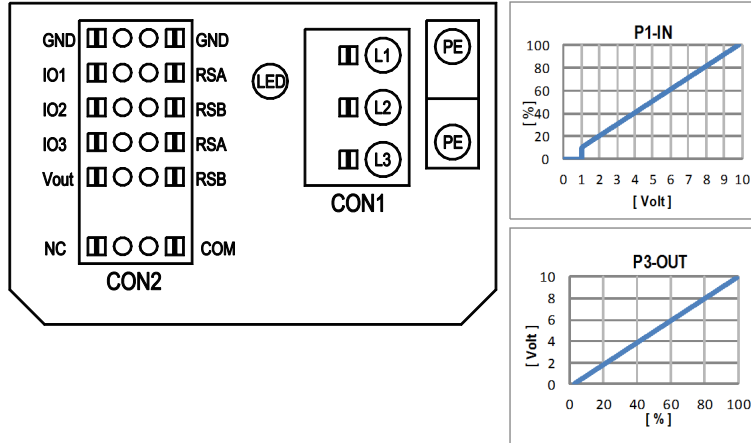

No.	Conn.	Designation	Function/assignment
	CON1	L1, L2, L3	Power supply, phase, see nameplate for voltage range
	PE	PE	Protective earth
	CON2	RSA	RS485 interface for MODBUS, RSA; SELV
	CON2	RSB	RS485 interface for MODBUS, RSB; SELV
	CON2	GND	Reference ground for control interface, SELV
	CON2	IO1	Function parameterizable (see "Optional interface functions" table) Factory setting: Digital input - high active, function: Disable input, SELV - inactive: Pin open or applied voltage < 1.5 VDC - active: applied voltage 3.5-50 VDC Reset function: Triggering of error reset on change of state from "enabled" to "disabled"
	CON2	IO2	Function parameterizable (see "Optional interface functions" table) Factory setting: Analog input 0-10 V / PWM, Ri=100 kΩ, function: Set value Characteristic curve parameterizable (see input characteristic curve P1-IN), SELV
	CON2	IO3	Function parameterizable (see "Optional interface functions" table) Factory setting: Analog output 0-10 V, max. 5 mA, function: Fan modulation level Characteristic curve parameterizable (see output characteristic curve P3-OUT), SELV
	CON2	Vout	Voltage output 3.3-24 VDC ±5%, Pmax=800 mW, voltage parameterizable Factory setting: 10 VDC short-circuit-proof, supply for external devices, SELV alternatively: 15-50 VDC input for parameterization via MODBUS without line voltage
	CON2	COM	Status relay, floating status contact, common connection, contact rating 250 VAC / 2 A (AC1) / min. 10 mA, reinforced insulation on supply side and on control interface side
	CON2	NC	Status relay, floating status contact, break for failure
		LED	green: status = good, ready for operation orange: status = warning red: status = failure
		P1-IN	Input characteristic curve
		P3-OUT	Output characteristic curve



EC axial fan - HyBlade

sickle-shaped blades (S series)

with guard grille for full nozzle

Terminal/plug assignment

CON2	configurable IO mode	electrical specification	configurable IO functions: normal / inverse
IO1	<ul style="list-style-type: none"> configurable option 	not active: pin open or applied voltage < 1.5VDC RI = 100k, characteristic curve parameterizable, $f_{PWM} = 1k..10kHz, SELV$	MODBUS Register for IO mode configuration D158 [0]
IO2	<ul style="list-style-type: none"> configurable option 	not active: pin open or applied voltage < 1.5VDC	
IO3	<ul style="list-style-type: none"> configurable option 	not active: pin open or applied voltage < 1.5VDC not active: pin open or applied voltage 3.5-50VDC PWM = 40Hz - 10kHz, characteristics parameterizable active: pin open or applied voltage 3.5-50VDC 40Hz - 10kHz, characteristics parameterizable active: applied voltage 3.5-50VDC not active: pin open or applied voltage < 1.5VDC, SELV	MODBUS Register for IO mode configuration D15A [8]
RSA	RS485 bus connection,	MODBUS RTU, specification V6.3, SELV	
Yout	alternatively: Input auxiliary power supply for parameterization via RS485/MODBUS RTU without line voltage	supply for external devices, SELV	D16E [..]

Terminal	Function	Signal	Direction	Notes
D101 [..]	source: set value		o	
D147 [..]	source: sensor value		o	
D104 [..]	switch: parameter set: #1 / #2		o	
D12E [..]	switch: control function: heating (pos.) / cooling (neg.)		o	
D148 [..]	switch: direction of rotation: cw / ccw		o	
D16C [..]	switch: set value source		o	
D16A [..]	switch: fan enable / disable		o	
(selected directly via IO mode)	signal: tach out			o
(selected directly via IO mode)	signal: diagnostics out			o
D130 [0]	signal: fan modulation level %		o	
D130 [1]	signal: actual speed		o	
D130 [2]	signal: system modulation level %		o	
D130 [5]	signal: remote control output 0-10V		o	
D00C [1]	pulse input for auto-addressing		o	
D130 [4]	pulse output for auto-addressing		o	



EC axial fan - HyBlade

sickle-shaped blades (S series)

with guard grille for full nozzle

Curves: Air performance 50 Hz

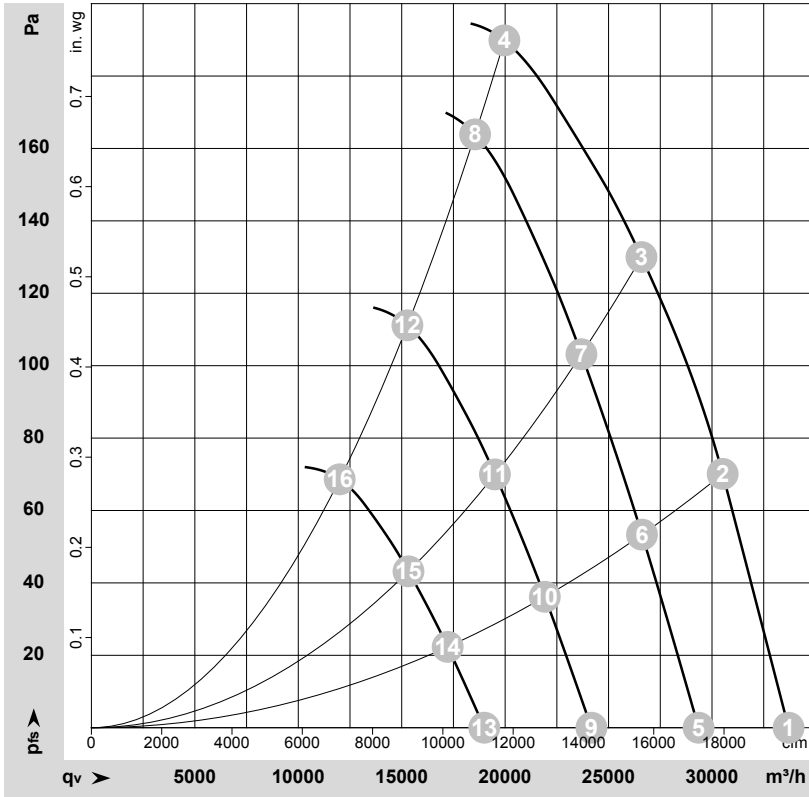

$\rho = 1.15 \text{ kg/m}^3 \pm 2 \%$

Measurement: LU-207295-1

Air performance measured according to ISO 5801 installation category A. For detailed information on the measurement setup, contact ebmpapst. Intake sound level: Sound power level according to ISO 13347 / sound pressure level measured at 1 m distance from fan axis. The values given are valid under the specified measuring conditions and may vary due to conditions of installation. For deviations from the standard configuration, the parameters have to be checked on the installed unit.

Measured values

	Wired	U	f	n	P _{ed}	I	LpA _{in}	LwA _{in}	LwA _{out}	q _v	p _{fs}	q _v	p _{fs}
		V	Hz	min ⁻¹	W	A	dB(A)	dB(A)	dB(A)	m ³ /h	Pa	cfm	in. wg
1	3~	400	50	970	1826	2.87	70	77	78	33705	0	19835	0.00
2	3~	400	50	970	2147	3.34	69	76	76	30515	70	17960	0.28
3	3~	400	50	955	2300	3.50	69	75	76	26590	130	15650	0.52
4	3~	400	50	920	2300	3.50	74	81	81	19965	190	11750	0.76
5	3~	400	50	850	1206	1.90	67	74	74	29350	0	17275	0.00
6	3~	400	50	850	1424	2.22	65	72	73	26615	53	15665	0.21
7	3~	400	50	850	1616	2.50	66	72	73	23690	103	13940	0.41
8	3~	400	50	850	1845	2.84	72	79	79	18550	164	10920	0.66
9	3~	400	50	700	674	1.06	62	69	69	24170	0	14225	0.00
10	3~	400	50	700	795	1.24	60	67	68	21920	36	12900	0.14
11	3~	400	50	700	903	1.40	61	68	68	19510	70	11480	0.28
12	3~	400	50	700	1030	1.59	67	74	74	15275	111	8990	0.45
13	3~	400	50	550	327	0.51	56	63	63	18995	0	11180	0.00
14	3~	400	50	550	386	0.60	54	61	62	17220	22	10135	0.09
15	3~	400	50	550	438	0.68	55	62	62	15325	43	9020	0.17
16	3~	400	50	550	500	0.77	61	68	68	12000	69	7065	0.28

Wired = Wiring · U = Voltage · f = Frequency · n = Speed (rpm) · P_{ed} = Power consumption · I = Current draw · LpA_{in} = Sound pressure level intake side · LwA_{in} = Sound power level intake side
 LwA_{out} = Sound power level outlet side · q_v = Air flow · p_{fs} = Pressure increase

