

AC axial fan - HyBlade

sickle-shaped blades (S series)

with guard grille for short nozzle

ASIA PACIFIC SHENGRUI LIMITED

Phone +00852 56261528

info@apacshengrui.com

www.apacfan.com



Nominal data

Type	S4D560-AR03-03						
Motor	M4D110-IA						
Phase		3~	3~	3~	3~	3~	3~
Nominal voltage	VAC	230	230	277	400	400	480
Wiring		Δ	Δ	Δ	Y	Y	Y
Frequency	Hz	50	60	60	50	60	60
Method of obtaining data		ml	ml	ml	ml	ml	ml
Valid for approval/standard		CE	CE	CE	CE	CE	CE
Speed (rpm)	min ⁻¹	1390	1575	1640	1390	1575	1640
Power consumption	W	880	1320	1420	880	1320	1420
Current draw	A	3.72	4.26	4.39	2.15	2.46	2.54
Max. back pressure	Pa	170	215	230	170	215	230
Max. back pressure	inH ₂ O	0.68	0.86	0.92	0.68	0.86	0.92
Min. ambient temperature	°C	-40	-40	-40	-40	-40	-40
Max. ambient temperature	°C	65	65	65	65	65	65
Starting current	A	17	15	19	10	8.9	11.2

ml = Max. load · me = Max. efficiency · fa = Free air · cs = Customer specification · ce = Customer equipment
Subject to change

Data according to ErP Directive

	Actual	Req. 2015				
01 Overall efficiency η_{es}	%	36.1	33.3	09 Power consumption P_e	kW	0.87
02 Measurement category	A			09 Air flow q_v	m ³ /h	6755
03 Efficiency category	Static			09 Pressure increase p_{fs}	Pa	169
04 Efficiency grade N	42.8	40		10 Speed (rpm) n	min ⁻¹	1390
05 Variable speed drive	No			11 Specific ratio*		1.00

Data obtained at optimum efficiency level.
The ErP data is determined using a motor-impeller combination in a standardized measurement setup.

* Specific ratio = $1 + p_{fs} / 100\,000\text{ Pa}$

LU-110536



AC axial fan - HyBlade

sickle-shaped blades (S series)

with guard grille for short nozzle

Technical description

Weight	16.1 kg
Fan size	560 mm
Rotor surface	Cast in aluminum
Terminal box material	PC/ABS plastic
Blade material	Sheet aluminum insert, sprayed with PP plastic
Guard grille material	Steel, coated with black plastic (RAL 9005)
Number of blades	5
Blade pitch	-10°
Airflow direction	"V"
Direction of rotation	Counterclockwise, viewed toward rotor
Degree of protection	IP54
Insulation class	"F"
Moisture (F) / Environmental (H) protection class	F3-1
Max. permitted ambient temp. for motor (transport/storage)	+80 °C
Min. permitted ambient temp. for motor (transport/storage)	-40 °C
Installation position	Shaft horizontal or rotor on bottom; rotor on top on request
Condensation drainage holes	On rotor side
Mode	S1
Motor bearing	Ball bearing
Touch current according to IEC 60990 (measuring circuit Fig. 4, TN system)	<= 3.5 mA
Electrical hookup	Via terminal box
Motor protection	Thermal overload protector (TOP) with basic insulation
With cable	Axial
Protection class	I (with customer connection of protective earth)
Conformity with standards	EN 61800-5-1; CE
Approval	VDE; EAC; UL 1004-1; CSA C22.2 No. 100

AC axial fan - HyBlade

sickle-shaped blades (S series)
with guard grille for short nozzle

Product drawing

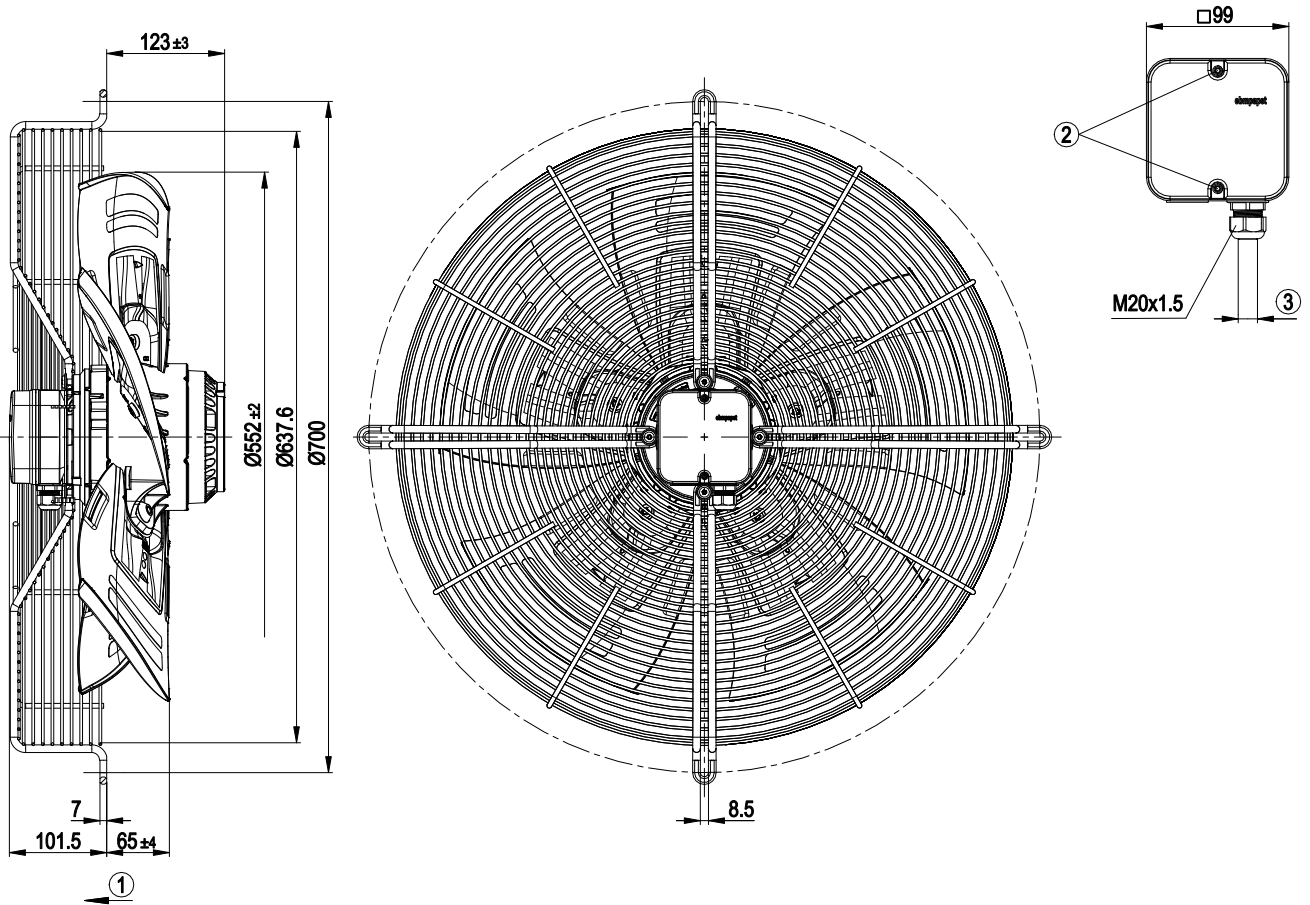

1	Direction of air flow "V"
2	Tightening torque 1.5 ± 0.2 Nm
3	Cable diameter min. 6 mm, max. 12 mm, tightening torque 2 ± 0.3 Nm



AC axial fan - HyBlade

sickle-shaped blades (S series)
with guard grille for short nozzle

Connection diagram

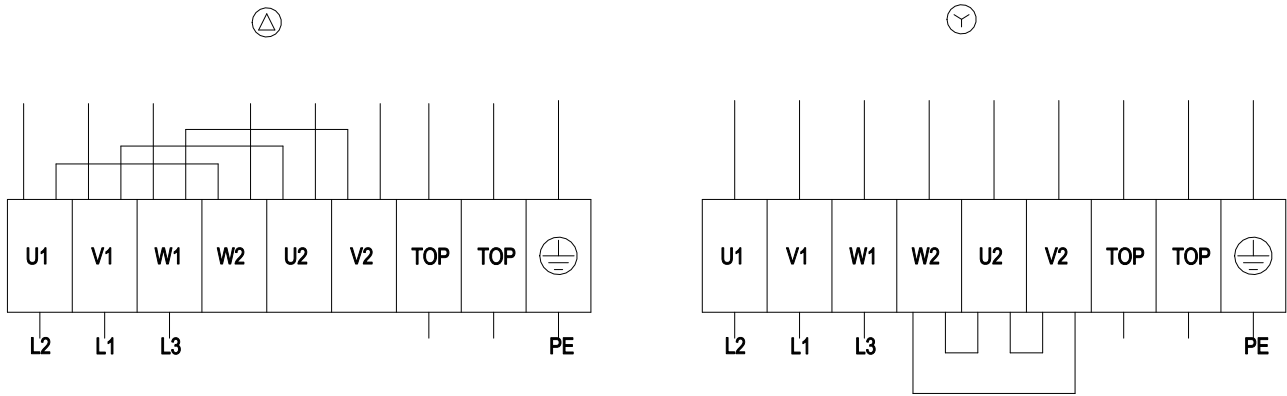

Δ	Delta connection	Y	Star connection	L1	= V1 = blue
L2	= U1 = black	L3	= W1 = brown	W2	yellow
U2	green	V2	white	TOP	2x gray
PE	green/yellow				

AC axial fan - HyBlade

sickle-shaped blades (S series)
with guard grille for short nozzle

Curves: Air performance 50 Hz

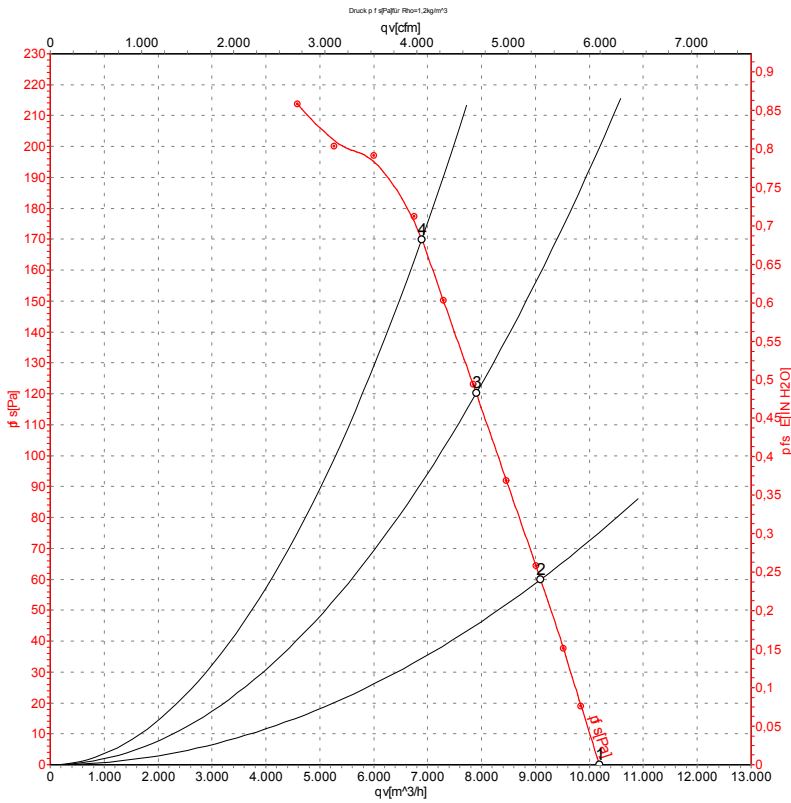

Measurement: LU-110536-1

Air performance measured according to ISO 5801 installation category A. For detailed information on the measurement setup, contact ebm-papst. Intake sound level: Sound power level according to ISO 13347 / sound pressure level measured at 1 m distance from fan axis. The values given are valid under the specified measuring conditions and may vary due to conditions of installation. For deviations from the standard configuration, the parameters have to be checked on the installed unit.

Measured values

	Wired	U	f	n	P _e	I	LpA _{in}	LwA _{in}	LwA _{out}	qv	p _{fs}	qv	p _{fs}
		V	Hz	min ⁻¹	W	A	dB(A)	dB(A)	dB(A)	m ³ /h	Pa	CFM	inH ₂ O
1	Y	400	50	1435	604	1.88	72	78	78	10190	0	6000	0.00
2	Y	400	50	1420	711	1.95	68	74	74	9095	60	5355	0.24
3	Y	400	50	1400	810	2.04	70	76	75	7900	120	4650	0.48
4	Y	400	50	1390	880	2.15	70	77	76	6890	170	4055	0.68

Wired = Wiring · U = Power supply · f = Frequency · n = Speed (rpm) · P_e = Power consumption · I = Current draw · LpA_{in} = Sound pressure level intake side · LwA_{in} = Sound power level intake side
LwA_{out} = Sound power level outlet side · qv = Air flow · p_{fs} = Pressure increase



AC axial fan - HyBlade

sickle-shaped blades (S series)

with guard grille for short nozzle

Curves: Air performance 60 Hz

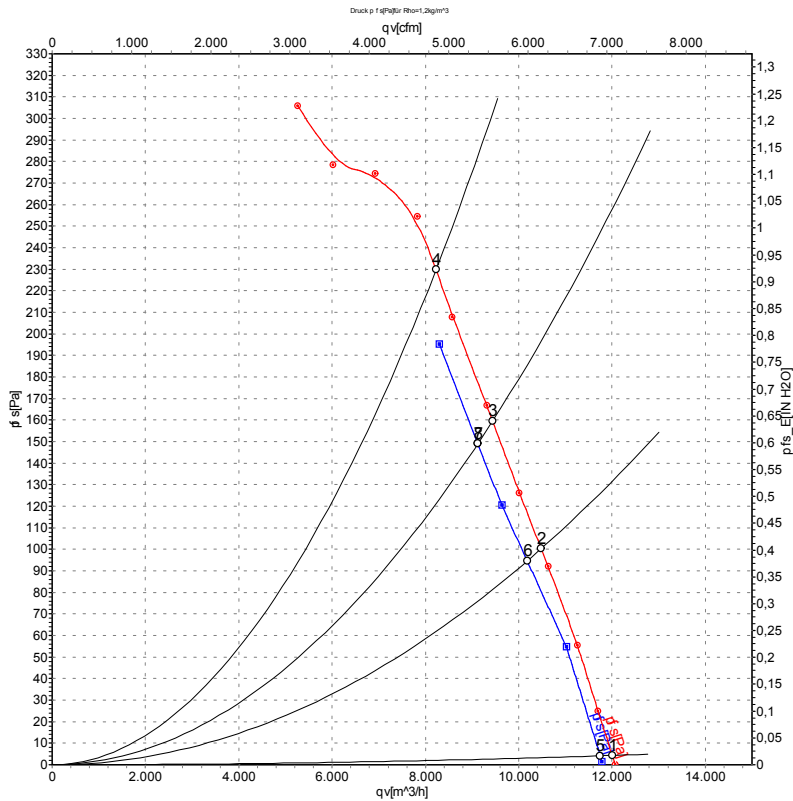

Measurement: LU-110544-1
Measurement: LU-111437-1

Air performance measured according to ISO 5801 installation category A. For detailed information on the measurement setup, contact ebm-papst. Intake sound level: Sound power level according to ISO 13347 / sound pressure level measured at 1 m distance from fan axis. The values given are valid under the specified measuring conditions and may vary due to conditions of installation. For deviations from the standard configuration, the parameters have to be checked on the installed unit.

Measured values

	Wired	U	f	n	P _e	I	LpA _{in}	LwA _{in}	LwA _{out}	η _{es}	qv	p _{fs}	qv	p _{fs}
		V	Hz	min ⁻¹	W	A	dB(A)	dB(A)	dB(A)	%	m ³ /h	Pa	CFM	inH ₂ O
1	Y	480	60	1705	968	2.02	75	81	81	44	12010	0	7070	0.00
2	Y	480	60	1675	1175	2.18	72	79	78	47	10480	100	6170	0.40
3	Y	480	60	1660	1296	2.30	74	79	79	46	9440	160	5555	0.64
4	Y	480	60	1640	1420	2.54	75	81	80	45	8140	230	4790	0.92
5	Y	400	60	1665	898	1.79	75	81	81	45	11750	0	6915	0.00
6	Y	400	60	1625	1085	2.02	72	78	77	47	10180	95	5990	0.38
7	Y	400	60	1605	1188	2.16	72	78	78	45	9125	149	5370	0.60
8	Y	400	60	1575	1320	2.46	75	80		45	7600	215	4475	0.86

Wired = Wiring · U = Power supply · f = Frequency · n = Speed (rpm) · P_e = Power consumption · I = Current draw · LpA_{in} = Sound pressure level intake side · LwA_{in} = Sound power level intake side
LwA_{out} = Sound power level outlet side · η_{es} = Total efficiency of fan · qv = Air flow · p_{fs} = Pressure increase

