

AC axial fan - HyBlade

sickle-shaped blades (S series)

with guard grille for short nozzle

ASIA PACIFIC SHENGRUI LIMITED

Phone +00852 56261528

info@apacshengrui.com

www.apacfan.com

Nominal data

Type	S6D710-AH03-03						
Motor	M6D138-HF						
Phase		3~	3~	3~	3~	3~	3~
Nominal voltage	VAC	230	230	277	400	400	480
Wiring		Δ	Δ	Δ	Y	Y	Y
Frequency	Hz	50	60	60	50	60	60
Method of obtaining data		ml	ml	ml	ml	ml	ml
Valid for approval/standard		CE	CE	CE	CE	CE	CE
Speed (rpm)	min ⁻¹	910	995	1060	910	995	1060
Power consumption	W	990	1470	1620	990	1470	1620
Current draw	A	3.98	4.92	4.95	2.3	2.84	2.85
Max. back pressure	Pa	115	140	160	115	140	160
Max. back pressure	in. wg	0.46	0.56	0.64	0.46	0.56	0.64
Min. ambient temperature	°C	-40	-40	-40	-40	-40	-40
Max. ambient temperature	°C	70	65	65	70	65	65
Starting current	A	15	13	17	9.0	7.5	10

ml = Max. load · me = Max. efficiency · fa = Free air · cs = Customer specification · ce = Customer equipment
Subject to change

Data according to Commission Regulation (EU) 327/2011 (EN 17166)

	Actual	Req. 2015				
01 Overall efficiency η_{es}	%	34.3	33.6	09 Power consumption P_e	kW	0.96
02 Measurement category		A		09 Air flow q_v	m ³ /h	11750
03 Efficiency category		Static		09 Pressure increase p_{fs}	Pa	102
04 Efficiency grade N		40.7	40	10 Speed (rpm) n	min ⁻¹	915
05 Variable speed drive		No		11 Specific ratio*		1.00

Data obtained at optimum efficiency level.
The ErP data is determined using a motor-impeller combination in a standardized measurement setup.

* Specific ratio = $1 + p_{fs} / 100\,000\text{ Pa}$

LU-199681



AC axial fan - HyBlade

sickle-shaped blades (S series)

with guard grille for short nozzle

Technical description

Weight	26.7 kg
Size	710 mm
Motor size	138
Rotor surface	Cast in aluminum
Terminal box material	PP plastic
Blade material	Sheet aluminum insert, sprayed with PP plastic
Guard grille material	Steel, coated with black plastic (RAL 9005)
Number of blades	5
Blade pitch	-5°
Airflow direction	V
Direction of rotation	Clockwise, viewed toward rotor
Degree of protection	IP54
Insulation class	"F"
Moisture (F) / Environmental (H) protection class	H2
Ambient temperature note	Occasional start-up at temperatures between -40°C and -25°C is permitted. For continuous operation at ambient temperatures below -25°C (such as refrigeration applications), use must be made of a fan design with special low-temperature bearings.
Max. permitted ambient temp. for motor (transport/storage)	+80 °C
Min. permitted ambient temp. for motor (transport/storage)	-40 °C
Installation position	Any
Condensation drainage holes	On rotor and stator sides
Mode	S1
Motor bearing	Ball bearing
Touch current according to IEC 60990 (measuring circuit Fig. 4, TN system)	<= 3.5 mA
Electrical hookup	Terminal box
Motor protection	Thermal overload protector (TOP) with basic insulation
With cable	Axial
Protection class	I (with customer connection of protective earth)
Conformity with standards	EN 60034-1 (2010); CE
Approval	CSA C22.2 No. 100; EAC; UL 1004-1

AC axial fan - HyBlade

sickle-shaped blades (S series)
with guard grille for short nozzle

Product drawing

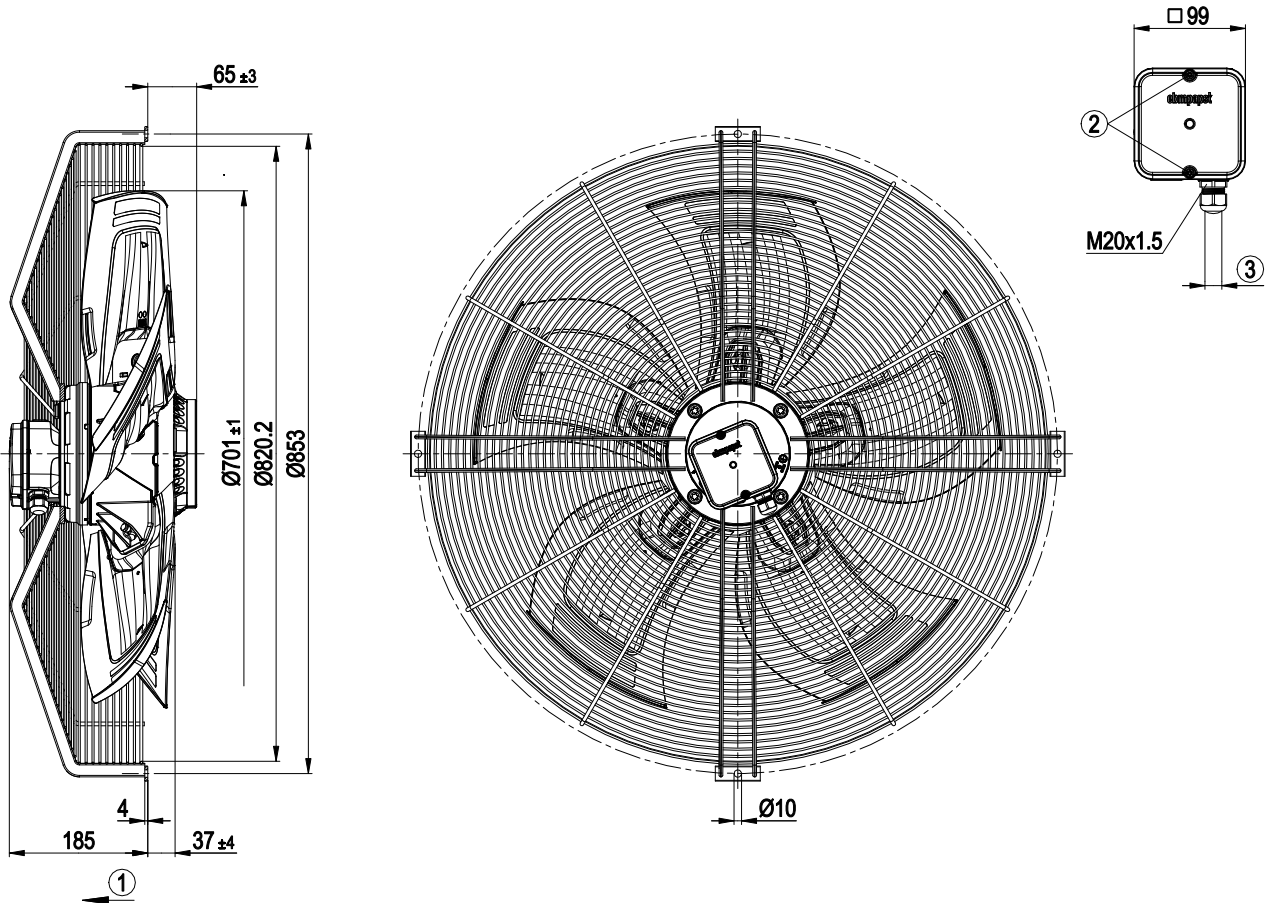

1	Direction of air flow "V"
2	Tightening torque 1.5 ± 0.2 Nm
3	Cable diameter min. 7 mm, max. 14 mm, tightening torque 2 ± 0.3 Nm

AC axial fan - HyBlade

sickle-shaped blades (S series)
with guard grille for short nozzle

Connection diagram

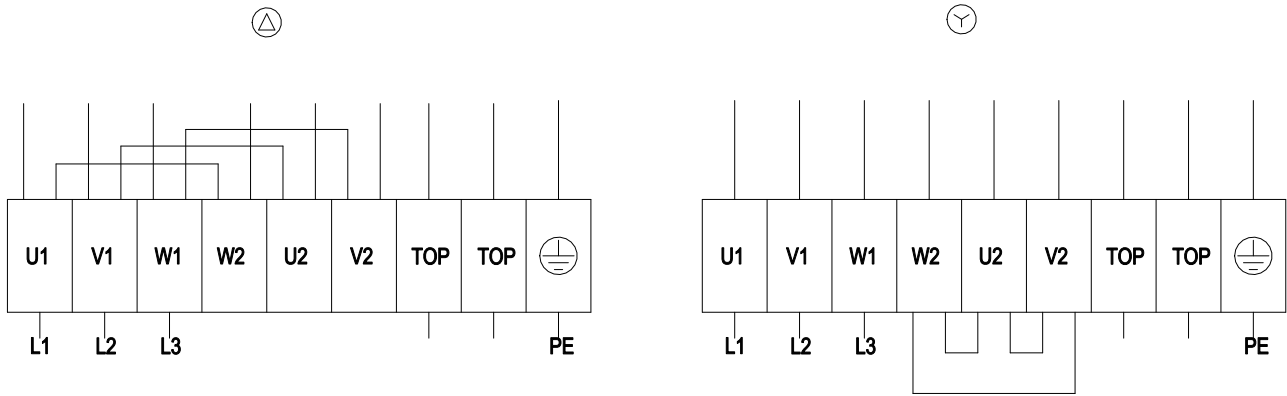

Δ	Delta connection	Y	Star connection	L1	= U1 = black
L2	= V1 = blue	L3	= W1 = brown	W2	yellow
U2	green	V2	white	TOP	2x gray
PE	green/yellow				

AC axial fan - HyBlade

sickle-shaped blades (S series)
with guard grille for short nozzle

Curves: Air performance 50 Hz

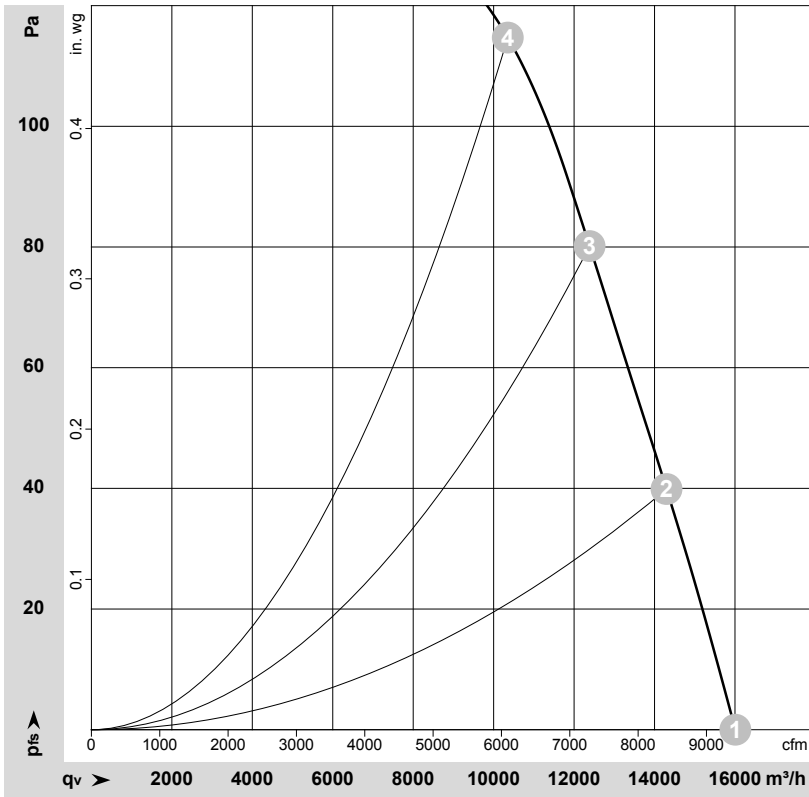

$\rho = 1.15 \text{ kg/m}^3 \pm 2 \%$

Measurement: LU-121549-1

Air performance measured according to ISO 5801 installation category A. For detailed information on the measurement setup, contact ebm-papst. Intake sound level: Sound power level according to ISO 13347 / sound pressure level measured at 1 m distance from fan axis. The values given are valid under the specified measuring conditions and may vary due to conditions of installation. For deviations from the standard configuration, the parameters have to be checked on the installed unit.

Measured values

	Wired	U	f	n	P _e	I	LpA _{in}	LwA _{in}	LwA _{out}	q _v	p _{fs}	q _v	p _{fs}
		V	Hz	min ⁻¹	W	A	dB(A)	dB(A)	dB(A)	m ³ /h	Pa	cfm	in. wg
1	Y	400	50	940	722	2.02	63	70	70	16010	0	9425	0.00
2	Y	400	50	925	823	2.12	62	69	68	14300	40	8415	0.16
3	Y	400	50	915	921	2.22	62	69	68	12385	80	7290	0.32
4	Y	400	50	910	990	2.30	66	73	72	10350	115	6095	0.46

Wired = Wiring · U = Voltage · f = Frequency · n = Speed (rpm) · P_e = Power consumption · I = Current draw · LpA_{in} = Sound pressure level intake side · LwA_{in} = Sound power level intake side
LwA_{out} = Sound power level outlet side · q_v = Air flow · p_{fs} = Pressure increase



AC axial fan - HyBlade

sickle-shaped blades (S series)
with guard grille for short nozzle

Curves: Air performance 60 Hz

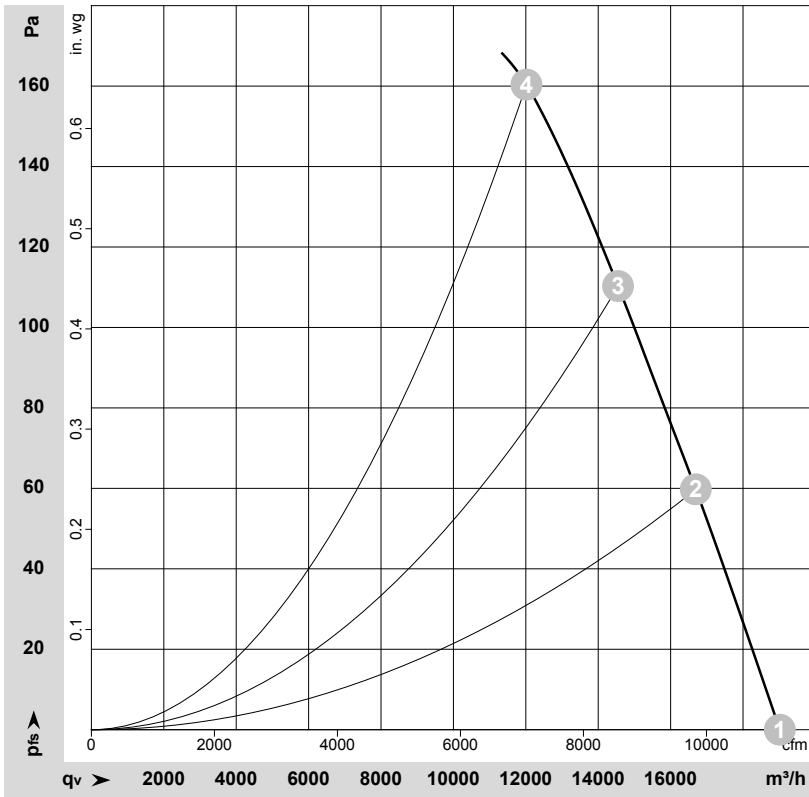

$\rho = 1.15 \text{ kg/m}^3 \pm 2 \%$

Measurement: LU-121556-1

Air performance measured according to ISO 5801 installation category A. For detailed information on the measurement setup, contact ebm-papst. Intake sound level: Sound power level according to ISO 13347 / sound pressure level measured at 1 m distance from fan axis. The values given are valid under the specified measuring conditions and may vary due to conditions of installation. For deviations from the standard configuration, the parameters have to be checked on the installed unit.

Measured values

	Wired	U	f	n	P _e	I	LpA _{in}	LwA _{in}	LwA _{out}	q _v	p _{fs}	q _v	p _{fs}
		V	Hz	min ⁻¹	W	A	dB(A)	dB(A)	dB(A)	m ³ /h	Pa	cfm	in. wg
1	Y	480	60	1105	1172	2.30	67	74	74	19015	0	11190	0.00
2	Y	480	60	1090	1351	2.49	66	73	73	16695	60	9825	0.24
3	Y	480	60	1075	1489	2.65	66	73	73	14550	110	8565	0.44
4	Y	480	60	1060	1620	2.85	71	77	77	12015	160	7075	0.64

Wired = Wiring · U = Voltage · f = Frequency · n = Speed (rpm) · P_e = Power consumption · I = Current draw · LpA_{in} = Sound pressure level intake side · LwA_{in} = Sound power level intake side
LwA_{out} = Sound power level outlet side · q_v = Air flow · p_{fs} = Pressure increase

